

# One-Dimensional Synthesis of Graphs as Tensegrity Frameworks

András RECSKI\* and Offer SHAI†

February 15, 2005

## 1 Abstract

The edge set of a graph  $G$  is partitioned into two subsets  $E_C \cup E_S$ . A tensegrity framework with underlying graph  $G$  and with cables for  $E_C$  and struts for  $E_S$  is proved to be rigidly embeddable into a 1-dimensional line if and only if  $G$  is 2-edge-connected and every 2-vertex-connected component of  $G$  intersects both  $E_C$  and  $E_S$ . Polynomial algorithms are given to find an embedding of such graphs and to check the rigidity of a given 1-dimensional embedding.

## 2 Introduction

Tensegrity structures are pin-connected frameworks where some of the members are cables or struts. Today, tensegrity structures interest researchers in engineering, mathematical and biological communities.

In engineering, tensegrity structures provide efficient solutions in such applications as deployable structures [1, 2], shape-controllable structures, smart sensors [3] and lightweight structures.

---

\*Budapest University of Technology and Economics, Department of Computer Science and Information Theory, and Center for Applied Mathematics and Computational Physics, H-1521 Budapest, Hungary. Support of the Hungarian National Science Fund (Grant numbers OTKA 37547, 42559 and 44733) are gratefully acknowledged.

†Tel-Aviv University, Department of Mechanics Materials and Systems, Faculty of Engineering, Tel-Aviv, Israel.

The biological community employs tensegrity structures as models underlying the behavior of a number of biological entities, such as the cytoskeleton [4]. Adopting such models enables the biologists to interpret some observed but previously unexplained natural phenomena.

The complexity of the behavior on one hand and the special properties on the other are those providing the incentive for mathematical studies of tensegrity structures [5, 6]. The main interest in this respect is concentrated on the issues of checking rigidity [7, 8] and structural analysis of these structures.

A key problem in the design of tensegrity structures is the determination of geometrical configurations where a given structure becomes rigid. For now, this problem, also referred as the 'form-finding problem' [9], does not possess general analytical solution, except for some special relatively simple cases [10].

The present paper addresses a combinatorial approach for treating one-dimensional tensegrity structures, i.e. structures where all members are parallel. The paper establishes a theorem for checking the topological rigidity of these structures, i.e. deciding whether for a given graph there exists at least one rigid geometrical embedding. If yes, the paper provides a graph-theoretical algorithm for finding a rigid embedding for the given frame topology. This can be regarded as an alternative solution for the 'form-finding problem', although, for now, it is limited for one dimensional structures. Additionally, an algorithm for checking the rigidity of a structure with a given geometry is shown to be equivalent to checking whether the corresponding graph is strongly connected.

It is shown that the methodology can partly be considered as a special case of a more general theorem based on matroid theory [7], which raises the possibility that in the future the method could be expanded for multidimensional cases.

### 3 Condition for graph embeddability as rigid one-dimensional framework

Let  $G = (V, E)$  be a finite graph with vertex set  $V$  and edge set  $E$  and let  $\chi$  denote a bipartition  $E = E_C \cup E_S$ . A function  $f : V(G) \rightarrow \mathbb{R}$  is called a *one-dimensional embedding* of  $G$  if  $x \neq y$  implies  $f(x) \neq f(y)$ .

A function  $g : V(G) \rightarrow \mathbb{R}$  satisfying

$$|g(x) - g(y)| \begin{cases} \leq |f(x) - f(y)| & \text{if } \{x, y\} \in E_C \\ \geq |f(x) - f(y)| & \text{if } \{x, y\} \in E_S, \end{cases} \quad (1)$$

and

$$\text{sign}[g(x) - g(y)] = \text{sign}[f(x) - f(y)] \quad \forall \{x, y\} \in E \quad (2)$$

is called a *motion with respect to the bipartition*  $\chi$  or shortly a  $\chi$ -*motion* of the embedded graph  $G$ . Such a  $\chi$ -motion is *trivial* if there exists a constant  $c \in \mathbb{R}$  so that  $g(x) = f(x) + c$  for every  $x \in V(G)$ .

A one-dimensional embedding  $f$  is called a *one-dimensional rigid embedding* of  $G$  with respect to this bipartition, or shortly a *one-dimensional rigid  $\chi$ -embedding* if every  $\chi$ -motion of it is trivial.

A circuit  $C$  of the graph  $G$  is a *mixed circuit* with respect to a bipartition  $\chi$ , or shortly a  $\chi$ -*mixed circuit* if neither  $C \cap E_C$  nor  $C \cap E_S$  is empty.

*Theorem 1: A graph has a one-dimensional rigid  $\chi$ -embedding if and only if the graph is connected and every edge of it is contained by at least one  $\chi$ -mixed circuit.*

*Remark:* The elements of  $E_C$  and  $E_S$  can be interpreted as cables and struts, respectively, of a tensegrity framework with a given topology  $G$ . Since each edge, representing a rod can be replaced by a pair of edges, one representing a cable and one representing a strut, Theorem 1 essentially refers to tensegrity frameworks with all three types of elements. Observe that if a framework consists of rods only then the condition of the theorem reduces to the connectivity of the graph, a known condition described in the mathematical literature [11].

*Proof: I. Necessity.* The connectedness is obvious – if  $G_0$  were a connected component of a disconnected graph  $G$  then the function

$$g(x) = \begin{cases} f(x) + c_0 & \text{if } x \in V(G_0) \\ f(x) & \text{otherwise} \end{cases} \quad (3)$$

with  $c_0 \neq 0$  would be a nontrivial  $\chi$ -motion of  $G$ . Similarly, if the edge  $e = \{a, b\} \in E_S$  (or  $\in E_C$ , respectively) were a bridge of  $G$  and  $G_0$  denotes one of the components of  $G - e$  then the same function could be applied using a value of  $c_0$  so that  $|g(b) - g(a)|$  must be greater (smaller, respectively) than  $|f(b) - f(a)|$ .

Hence from now on we may suppose that  $G$  is connected and bridgeless. Consider one of its 2-connected components  $G_0$  and suppose indirectly that it has no  $\chi$ -mixed circuits, that is, all of its edges are in, say,  $E_C$ . Let  $x_0$  be a vertex of  $V(G_0)$  so that  $f(x_0)$  is an internal point of the interval spanned by the values  $\{f(v)|v \in V(G_0)\}$ . Then  $g(x) = f(x_0) + c[f(x) - f(x_0)]$  with some  $c < 1$  applied for  $x \in V(G_0)$  and then extended by an appropriate constant translation for the remaining elements of  $V(G)$  would define a nontrivial  $\chi$ -motion of  $G$ . (If all of the edges of  $G_0$  were in  $E_S$  then use the same argument with  $c > 1$ .)

*II. Sufficiency.* If every edge of a connected graph  $G$  is contained in some circuits then  $G$  is clearly bridgeless. Hence it is either 2-connected or has a cactus-decomposition into 2-connected components. It is clearly enough to prove the embeddability for a single 2-connected component.

*Lemma 1.* *A single  $\chi$ -mixed circuit has a one-dimensional rigid  $\chi$ -embedding.*

*Proof:* We may suppose that struts and cables alternate in the circuit (otherwise replace temporarily a maximum path of struts or cables with a single strut (cable, respectively); after embedding this tensegrity framework into the one-dimensional space one can readily finish the original embedding by “subdividing” some struts and cables into smaller ones). Let  $[v_0, v_1, v_2, \dots, v_{k-1}, v_k = v_0]$  be a cyclic description of the vertices of the  $\chi$ -mixed circuit. Then

- Let  $f(v_0)$  be an arbitrary real number and  $i = 0$ .
- If  $i = k - 1$  then stop.
- If  $\{v_i, v_{i+1}\} \in E_C$  then “jump to the right”, that is, define  $f(v_{i+1})$  as an arbitrary value greater than any of the values  $f(v_0), f(v_1), \dots, f(v_i)$ .
- If  $\{v_i, v_{i+1}\} \in E_S$  then “jump to the left”, that is, define  $f(v_{i+1})$  as an arbitrary value less than any of the values  $f(v_0), f(v_1), \dots, f(v_i)$ .
- Increase the value of  $i$  by one and go to the second step.

Figure 1 shows an example of a mixed circuit and its embedding obtained by means of this procedure:

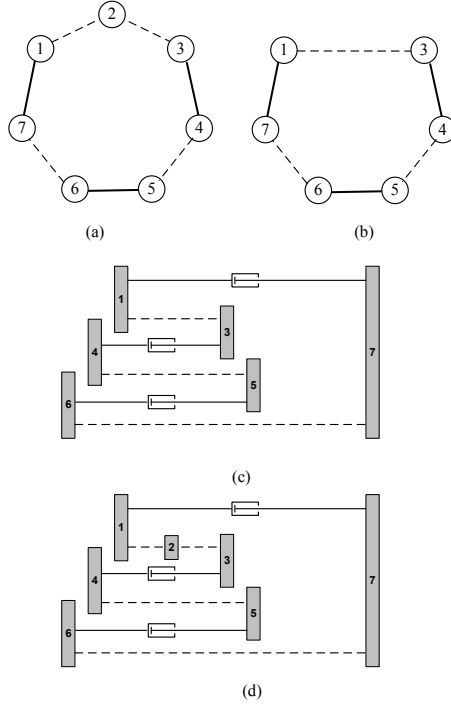

Figure 1: Example of a rigid embedding of a mixed circuit: (a) the mixed circuit; (b) reducing the circuit to an alternating form; (c) rigid embedding of the reduced mixed circuit; (d) the rigid embedding of the original circuit (with the corresponding cable 'subdivided').

In order to prove the rigidity of this embedding, consider a motion  $g(x)$  of the obtained system. Without loss of generality we may suppose that  $\{v_1, v_2\} \in E_S$ , thus by Eq. (1), the following set of inequalities is satisfied:

$$\begin{aligned}
 |g(v_1) - g(v_2)| &\geq |f(v_1) - f(v_2)| \\
 |g(v_2) - g(v_3)| &\leq |f(v_2) - f(v_3)| \\
 &\dots \\
 |g(v_k) - g(v_1)| &\leq |f(v_k) - f(v_1)|
 \end{aligned} \tag{4}$$

The definition of  $g(v)$  (Eq. 2) and the above synthesis procedure for  $\{v_i, v_j\} \in E_S$  imply that  $g(v_i) > g(v_j)$  and  $f(v_i) > f(v_j)$ , while those for  $\{v_i, v_j\} \in E_C$

imply that  $g(v_i) < g(v_j)$  and  $f(v_i) < f(v_j)$ . Therefore the above inequalities can now be rewritten without using the absolute values:

$$\begin{aligned}
g(v_1) - g(v_2) &\geq f(v_1) - f(v_2) \\
g(v_2) - g(v_3) &\geq f(v_2) - f(v_3) \\
&\dots \\
g(v_k) - g(v_1) &\geq f(v_k) - f(v_1)
\end{aligned} \tag{5}$$

Rearranging the terms in the above inequalities yields:

$$g(v_1) - f(v_1) \geq g(v_2) - f(v_2) \geq \dots \geq g(v_k) - f(v_k) \geq g(v_1) - f(v_1) \tag{6}$$

Obviously, this set of inequalities can be resolved only if  $g(x)$  is trivial with respect to  $f(x)$ , which proves that  $f(x)$  is a rigid embedding.  $\square$

*Lemma 2.* Suppose that a 2-connected proper subgraph  $G'$  of a 2-connected graph  $G$  has already a one-dimensional rigid  $\chi$ -embedding and let  $[v_0, v_1, \dots, v_k]$  be a path of  $G$  so that  $\{v_0, v_1, \dots, v_k\} \cap V(G') = \{v_0, v_k\}$ . Then this embedding can be extended to that of a subgraph containing  $G'$  and this path. (Here  $k \geq 1$ , hence we permit that a single edge is added only.)

*Proof:* Without loss of generality we may suppose that the edges of the path belong alternately to  $E_C$  and  $E_S$ , see the argument in the first paragraph of the proof of Lemma 1. If  $k = 1$  then simply insert the required tensegrity element between the two end points which were already in fixed positions. If  $k > 1$  then

- Let  $i = 0$ .
- If  $i = k - 1$  then stop.
- If  $\{v_i, v_{i+1}\} \in E_C$  then “jump to the right”, that is, define  $f(v_{i+1})$  as an arbitrary value greater than any of the values  $\{f(v_0), f(v_1), \dots, f(v_i)\} \cup \{f(v) | v \in V(G')\}$ .
- If  $\{v_i, v_{i+1}\} \in E_S$  then “jump to the left”, that is, define  $f(v_{i+1})$  as an arbitrary value less than any of the values  $\{f(v_0), f(v_1), \dots, f(v_i)\} \cup \{f(v) | v \in V(G')\}$ .

- Increase the value of  $i$  by one and go to the second step.

The rigidity of the resulting embedding can be proved in a similar fashion, as it was done for Lemma 1.  $\square$

Now *the proof of the sufficiency* is obvious by considering the cactus-decomposition of  $G$  and realizing the embedding of the individual 2-connected components as follows: Start with a mixed circuit as in Lemma 1 and then extend it gradually, as in Lemma 2, with new paths (including the possibility of single new edges as well).  $\square$

Figure 2 shows an example of realizing such embedding of a graph.

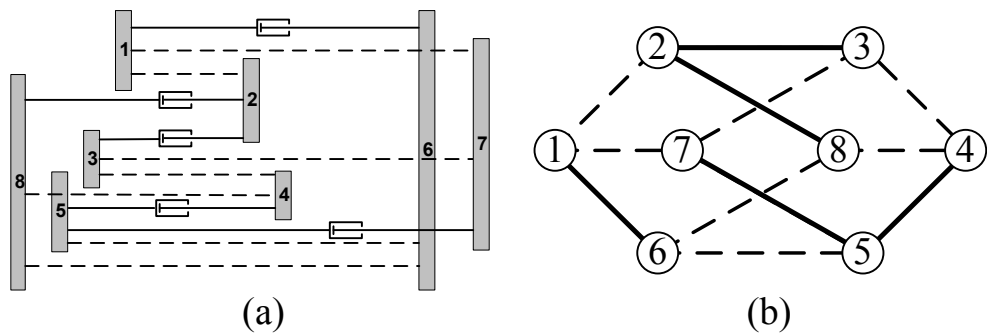

Figure 2: Example of a rigid embedding of a complex graph: (a) the rigid embedding; (b) the corresponding graph

## 4 Condition for rigidity of a given one-dimensional framework

Consider a one-dimensional embedding  $F$  of a tensegrity framework. The corresponding directed graph representation  $G_F$  is defined so that the vertices  $v_i$  of  $G_F$  correspond to the joints  $i$  of  $F$  and a tensegrity element between the joints  $i, j$  with  $f(v_i) < f(v_j)$  correspond to the edge  $e = \{i, j\}$  of  $G_F$ , with an orientation from  $i$  to  $j$  if  $e$  is a cable and from  $j$  to  $i$  if  $e$  is a strut.

By Eq.(1), a function  $g(x)$  is a valid motion function with respect to  $G_F$  if:

$$g(h) - g(t) \geq f(h) - f(t) \quad \forall e = (t, \vec{h}) \in G_F \quad (7)$$

*Theorem 2: A given one-dimensional tensegrity framework  $F$  is rigid if and only if the corresponding directed graph  $G_F$  is strongly connected.*

*Proof: I. Necessity.* Let us suppose indirectly that  $G_F$  possesses a directed cut-set which separates  $G_F$  into two connected subgraphs,  $G_h$  and  $G_t$ , connected respectively to the head and the tail vertices of the edges belonging to the cut-set. Then the function:

$$g(x) = \begin{cases} f(x) + c_0 & \text{if } x \in G_h \\ f(x) & \text{if } x \in G_t \end{cases} \quad (8)$$

with  $c_0 \neq 0$  would be a valid nontrivial motion of  $F$ .

*II. Sufficiency.* Any two vertices  $u, v \in V(G_F)$  belong to a common directed circuit  $\{v, v_2, \dots, u, \dots, v_k, v\}$ . Applying Eq. (7) to the edges of the circuit yields a system of inequalities identical to Eq. (5). Again, this set of inequalities implies that the members and the joints corresponding to the circuit form a rigid framework not allowing relative displacement between  $u$  and  $v$ . As the condition is satisfied for any two joints of the framework, the framework as a whole is also rigid.  $\square$

It is interesting to note that Theorem 2 can be considered a special case of a more general theorem developed by the first author on the basis of matroid theory. We recall Theorem 18.3.2 in [7], referring to tensegrity frameworks of any dimension.

*Theorem 3: Let  $F$  be a tensegrity framework and suppose that the underlying system  $F'$  is rigid (i.e. dynamically determined). Suppose that the oriented matroid  $\mathbf{M}(F)$  is graphic and is described by a directed graph  $G$ . Then  $F$  is rigid if and only if the tensegrity transformation of  $G$  is strongly connected.*

$\mathbf{M}(F)$  in Theorem 3 is the oriented matroid represented by the row vectors of the rigidity matrix of the tensegrity framework  $F$  and the tensegrity transformation of  $G$  reverses the orientation of the edges corresponding to struts.

In the one-dimensional case the rigidity matrix is actually the transposed incidence matrix of  $F$ , where each column is multiplied by the length of the corresponding member. Thus, in this case,  $\mathbf{M}(F)$  is always a graphic matroid, determined by  $G_F$  itself.



## References

- [1] Tibert, G. (2002), *Deployable Tensegrity Structures for Space Applications*, PhD. Thesis. Royal Institute of Technology, Stockholm.
- [2] Guest, S. D. (1994), *Deployable Structures: Concepts and Analysis*, PhD. Thesis, Cambridge University.
- [3] Sultan, C., Skelton, R. (2004), A force and torque tensegrity sensor. *Sensors and Actuators A - Physical*, vol. A112, 2-3, 1 May 2004, 220-31.
- [4] Ingber, D. E. (1993), Cellular tensegrity: defining new rules of biological design that govern the cytoskeleton, *Journal of Cell Science*, 104, 613-627.
- [5] Asimow, L., Roth B. (1978), The rigidity of graphs, *Trans. Amer. Math. Soc.* 245, 279-289.
- [6] Asimow, L., Roth B. (1979), The rigidity of graphs II, *SIAM J. Appl. Math.* 68 1, 171-190.
- [7] Recski, A. (1989), *Matroid Theory and its Applications in Electric Network Theory and in Statics*, Springer, Berlin.
- [8] Connelly, R., Whiteley, W. (1996), Second-order rigidity and prestress stability for tensegrity frameworks. *SIAM J. Discrete Math.*, 9, 453-491.
- [9] Tibert, A G., Pellegrino, S. (2003), Review of form-finding methods for tensegrity structures, *Space Structures*, 18, 4, 209-223.
- [10] Connelly, R., Terrell, M. (1995), Globally rigid symmetric tensegrities, *Structural Topology*, 21, 59-78.
- [11] Lovász, L., Yemini, Y. (1982), On generic rigidity in the plane, *SIAM J. Alg. Discrete Methods*, 3, 1, 91-98.