

# Fixed-parameter tractability of multicut parameterized by the size of the cutset\*

Dániel Marx<sup>†</sup>      Igor Razgon<sup>‡</sup>

August 27, 2013

## Abstract

Given an undirected graph  $G$ , a collection  $\{(s_1, t_1), \dots, (s_k, t_k)\}$  of pairs of vertices, and an integer  $p$ , the EDGE MULTICUT problem asks if there is a set  $S$  of at most  $p$  edges such that the removal of  $S$  disconnects every  $s_i$  from the corresponding  $t_i$ . VERTEX MULTICUT is the analogous problem where  $S$  is a set of at most  $p$  vertices. Our main result is that both problems can be solved in time  $2^{O(p^3)} \cdot n^{O(1)}$ , i.e., fixed-parameter tractable parameterized by the size  $p$  of the cutset in the solution. By contrast, it is unlikely that an algorithm with running time of the form  $f(p) \cdot n^{O(1)}$  exists for the directed version of the problem, as we show it to be W[1]-hard parameterized by the size of the cutset.

## 1 Introduction

From the classical results of Ford and Fulkerson on minimum  $s - t$  cuts [20] to the more recent  $O(\sqrt{\log n})$ -approximation algorithms for sparsest cut problems [44, 1, 18], the study of cut and separation problems have a deep and rich theory. One well-studied problem in this area is the EDGE MULTICUT problem: given a graph  $G$  and pairs of vertices  $(s_1, t_1), \dots, (s_k, t_k)$ , remove a minimum set of edges such that every  $s_i$  is disconnected from its corresponding  $t_i$  for every  $1 \leq i \leq k$ . For  $k = 1$ , EDGE MULTICUT is the classical  $s - t$  cut problem and can be solved in polynomial time. For  $k = 2$ , EDGE MULTICUT remains polynomial-time solvable [46], but it becomes NP-hard for every fixed  $k \geq 3$  [15]. EDGE MULTICUT can be approximated within a factor of  $O(\log k)$  in polynomial time [22] (even in the weighted case where the goal is to minimize the total weight of the removed edges). However, under the Unique Games Conjecture of Khot [29], no constant factor approximation is possible [7]. One can analogously define the VERTEX MULTICUT problem, where the task is to remove a minimum set of vertices. An easy reduction shows that the vertex version is more general than the edge version.

Using brute force, one can decide in time  $n^{O(p)}$  if a solution of size at most  $p$  exists. Our main result is a more efficient exact algorithm for small values of  $p$  (the  $O^*$  notation hides factors that are polynomial in the input size):

**Theorem 1.1.** *Given an instance of VERTEX MULTICUT or EDGE MULTICUT and an integer  $p$ , one can find in time  $O^*(2^{O(p^3)})$  a solution of size  $p$ , if such a solution exists.*

---

\*A preliminary version of the paper was presented at STOC 2011 [37]. Research of the second author was supported by the European Research Council (ERC) grant “PARAMTIGHT: Parameterized complexity and the search for tight complexity results,” reference 280152.

<sup>†</sup>Institute for Computer Science and Control, Hungarian Academy of Sciences (MTA SZTAKI), [dmarx@cs.bme.hu](mailto:dmarx@cs.bme.hu)

<sup>‡</sup>Department of Computer Science and Information Systems, Birkbeck, University of London. [igor@dcs.bbk.ac.uk](mailto:igor@dcs.bbk.ac.uk)

That is, we prove that VERTEX MULTICUT and EDGE MULTICUT are fixed-parameter tractable parameterized by the size  $p$  of the solution, resolving a very challenging open question in the area of parameterized complexity. (Recall that a problem is *fixed-parameter tractable* (FPT) with a particular parameter  $p$  if it can be solved in time  $f(p) \cdot n^{O(1)}$ , where  $f$  is an arbitrary computable function depending only on  $p$ ; see [17, 19, 39] for more background). The question was first asked explicitly perhaps in [34]; it has been restated more recently as an open problem in e.g., [25, 8]. Our result shows in particular that multicut is polynomial-time solvable if the size of the optimum solution is  $O(\sqrt[3]{\log n})$  (where  $n$  is the input size).

One reason why multicut is a fundamental problem is that it is able to express several other problems. It has been observed that a correlation clustering problem called FUZZY CLUSTER EDITING can be reduced to (and in fact, equivalent with) EDGE MULTICUT [3, 16, 2]. Our results show that FUZZY CLUSTER EDITING is FPT parameterized by the editing cost, settling this open problem discussed e.g., in [3].

**Previous work.** The fixed-parameter tractability of multicut and related problems has been thoroughly investigated in the literature. EDGE MULTICUT is NP-hard on trees, but it is known to be FPT, parameterized by the maximum number  $p$  of edges that can be deleted, and admits a polynomial kernel [5, 26]. Multicut problems were studied in [25] for certain restricted classes of graphs. For general graphs, VERTEX MULTICUT is FPT if both  $p$  and the number of terminal pairs  $k$  are chosen as parameters (i.e, the problem can be solved in time  $f(p, k) \cdot n^{O(1)}$  [35, 45, 24] for some function  $f$ ). The algorithm of Theorem 1.1 is superior to these result in the sense that the running time depends polynomially on the number  $k$  of terminals pairs, and the exponential dependence is restricted to the parameter  $p$ , the number of deletions. For the special case of MULTIWAY CUT (where terminals in a set  $T$  have to be pairwise separated from each other), algorithms with running time of the form  $f(p) \cdot n^{O(1)}$  were already known [35, 8, 24], but apparently these algorithms do not generalize in an easy way to multicut. An FPT 2-approximation algorithm was given in [36] for EDGE MULTICUT: in time  $O^*(2^{O(p \log p)})$ , one can find a solution of size  $2p$  if a solution of size  $p$  exists. There is no obvious FPT algorithm for the problem even on bounded-treewidth graphs, although one can obtain linear-time algorithms if the treewidth remains bounded after adding an edge  $s_i t_i$  for each terminal pair [23, 40]. A PTAS is known for bounded-degree graphs of bounded treewidth [6].

**Our techniques.** The first two steps of our algorithm follows [36]. We start by an opening step that is fairly standard in the design of FPT algorithms. Instead of solving the original VERTEX MULTICUT problem, we solve the compression version of the problem, where the input contains a solution  $W$  of size  $p + 1$ , and the task is to find a solution of size  $p$  (if exists). A standard argument called *iterative compression* [43, 28] shows that if the compression problem is FPT, then the original problem is FPT. Alternatively, we can use the polynomial-time approximation algorithm of Gupta [27], which produces a solution  $W$  of size  $p^2$  if a solution of size  $p$  exists. In this case,  $O(p^2)$  iterations of the compression algorithm gives a solution of size  $p$ .

Next, as in [36], we try to reduce the compression problem to ALMOST 2SAT (delete  $k$  clauses to make a 2-CNF formula satisfiable; also known as 2CNF DELETION), which is known to be FPT [42, 14, 41]. However, our 2SAT formulation is very different from the one in [36]: we introduce a single variable  $x_v$  only for each vertex of  $G$ , while in [36] there is a variable  $x_{v,w}$  for every vertex  $v \in V(G)$  and vertex  $w \in W$  of the initial solution. This simpler reduction to ALMOST 2SAT is correct only if the instance satisfies two quite special properties:

- (1) every component of  $G \setminus W$  is adjacent to at most two vertices of  $W$  (“has at most two legs”), and
- (2) there is a solution  $S$  such that every component of  $G \setminus S$  contains a vertex of  $W$  (“no vertex is isolated from  $W$  after removing the solution  $S$ ” or “no vertex is in the shadow of  $S$ ”).

The main part of the paper is devoted to showing how these properties can be achieved. In order to achieve property (1), we show by an analysis of cuts and performing appropriate branching steps that the set  $W$  can be extended in such a way that every component has at most two legs (Section 4). To achieve property (2), we describe a nontrivial way of sampling random subset of vertices such that if we remove this subset by a certain contraction operation (taking the torso of the graph), then without changing the solution, we get rid of the parts not reachable from  $W$  with some positive probability (Section 3). This random sampling uses the concept of “important separators,” which was introduced in [35], and has been implicitly used in [9, 42, 8] in the design of parameterized algorithms. We consider the random sampling of important separators the main new technical idea of the paper. This technique and its generalizations have turned out to be useful for other problems as well [11, 31, 12, 11, 10, 33, 30] and we expect it to have further application in the future.

**Directed graphs.** Having resolved the fixed-parameter tractability of VERTEX MULTICUT, the next obvious question is what happens on directed graphs. Note that for directed graphs, the edge and vertex versions are equivalent. In directed graphs, multicut becomes much harder to approximate: there is no polynomial-time  $2^{\log^{1-\epsilon} n}$ -approximation for any  $\epsilon > 0$ , unless  $\text{NP} \subseteq \text{ZPP}$  [13]. From the fixed-parameter tractability point of view, the directed version of the problem received particular attention because DIRECTED FEEDBACK VERTEX SET or DFVS (delete  $p$  vertices to make the graph acyclic) can be reduced to DIRECTED MULTICUT. The fixed-parameter tractability of DFVS had been a longstanding open question in the area of parameterized complexity until it was solved by Chen et al. [9] recently. The main idea that led to the solution is that DFVS can be reduced to a variant (in fact, special case) of DIRECTED MULTICUT called SKEW MULTICUT, where the task is to break every path from  $s_i$  to  $t_j$  for every  $i > j$ . By showing that SKEW MULTICUT is FPT parameterized by the size of the solution, Chen et al. [9] proved the fixed-parameter tractability of DFVS. We show in Section 6 that, unlike SKEW MULTICUT, the general DIRECTED MULTICUT problem is unlikely to be FPT.

**Theorem 1.2.** *DIRECTED MULTICUT is  $W[1]$ -hard parameterized by the size  $p$  of the solution.*

**Independent and followup work.** A preliminary version of this paper appeared in [37]; the current version contains essentially the same algorithm, but the terminology and organization of Section 5 were significantly changed. Independently from our work, Bousquet et al. [4] presented in the same volume a proof that MULTICUT is FPT parameterized by the size  $p$  of the solution. The two algorithms have certain parts in common: both reduce the problem to the compression version and both ensure that we have to deal with components having only two legs. However, the main part of the two algorithms are substantially different: the current paper introduces the technique of random sampling of important separators and uses it to reduce the problem to ALMOST 2SAT, while Bousquet et al. [4] uses an approach based on a series of problem-specific reductions to reduce the problem to 2SAT.

Subsequently to the first version of this paper, random sampling of important separators has been used in several other applications. For undirected graphs, the technique was used by Lokshtanov and Ramanujan [33] to solve a parity version of MULTIWAY CUT and by Chitnis et al. [10] to solve a homomorphism problem generalizing certain deletion problems. For directed graphs, even though DIRECTED MULTICUT is  $W[1]$ -hard parameterized by  $p$  (see Section 6), Chitnis et al. [11] proved that the special case DIRECTED MULTIWAY CUT (Given a set  $T$  of terminals, break every directed path between two different terminals by removing at most  $p$  edges/vertices) is FPT parameterized by  $p$ . A consequence of this result is that DIRECTED MULTICUT with  $k = 2$  is FPT parameterized by  $p$  is FPT. Kratsch et al. [30] proved that DIRECTED MULTICUT on directed acyclic graphs (DAGs) is FPT with combined parameters  $k$  and  $p$ , and strengthened our hardness result by showing that DIRECTED MULTICUT remains  $W[1]$ -hard parameterized by  $p$  even on DAGs. However, the

complexity of DIRECTED MULTICUT for  $k = 3$  or with combined parameters  $k$  and  $p$  remains an interesting open question.

Chitnis et al. [12] use the random sampling technique to show the fixed-parameter tractability of DIRECTED SUBSET FEEDBACK VERTEX SET. They present an abstract framework that formalizes under which conditions this technique can be used, and they improve the randomized selection and its analysis to obtain better success probability and improved running time.

A very different application of the technique is given by Lokshtanov and Marx [31] in the context of clustering problems. They study a family of clustering problems such as partitioning the vertices of an undirected graph into clusters of size at most  $p$  such that at most  $q$  edges leave each cluster. The problem boils down to being able to check whether a given vertex  $v$  is contained in such a cluster. It turns out that the random sampling of important separators technique can be used to show that this task (and therefore the original clustering problem) is FPT parameterized by  $q$  by reducing it to a knapsack-like problem.

## 2 Framework: compression, shadows, legs

Let  $G$  be an undirected graph and let  $\mathbf{T} = \{(s_1, t_1), \dots, (s_k, t_k)\}$  be a set of terminal pairs. We say that a set  $S \subseteq V(G)$  of vertices is a *multicut* of  $(G, \mathbf{T})$  if there is no component<sup>1</sup> of  $G \setminus S$  that contains both  $s_i$  and  $t_i$  for some  $1 \leq i \leq k$  (note that it is allowed that  $S$  contains  $s_i$  or  $t_i$ ). The central problem of the paper is the following:

### VERTEX MULTICUT

*Input:* A graph  $G$ , an integer  $p$ , and a set  $\mathbf{T}$  of pairs of vertices of  $G$ .  
*Output:* A multicut of  $(G, \mathbf{T})$  of size at most  $p$  or “NO” if no such multicut exists.

We prove the fixed-parameter tractability of VERTEX MULTICUT by a series of reductions (see Figure 1). First we argue that it is sufficient to solve an easier *solution compression* problem. Then we present two reductions that modify the problem in such a way that it is sufficient to look for solutions that are *shadowless* and we can assume that the instance is *bipedal*. The last step of the proof is reducing this special variant of the problem to ALMOST 2SAT.

### 2.1 Compression

The first step in the proof of Theorem 1.1 is a standard technique in the design of parameterized algorithms: we define and solve the *compression problem*, where it is assumed that the input contains a feasible solution of size larger than  $p$ . As this technique is standard (and in particular, we follow the approach of [36] for EDGE MULTICUT), we keep this section short and informal.

### MULTICUT COMPRESSION

*Input:* A graph  $G$ , an integer  $p$ , a set  $\mathbf{T}$  of pairs of vertices of  $G$ , and a multicut  $W$  of  $(G, \mathbf{T})$ .  
*Output:* A multicut of  $(G, \mathbf{T})$  of size at most  $p$ , or “NO” if no such multicut exists.

<sup>1</sup>Throughout this paper, when we refer to a component  $K$  of a graph, we consider the set of vertices of this component. We omit saying “the set of vertices of” for the sake of brevity.

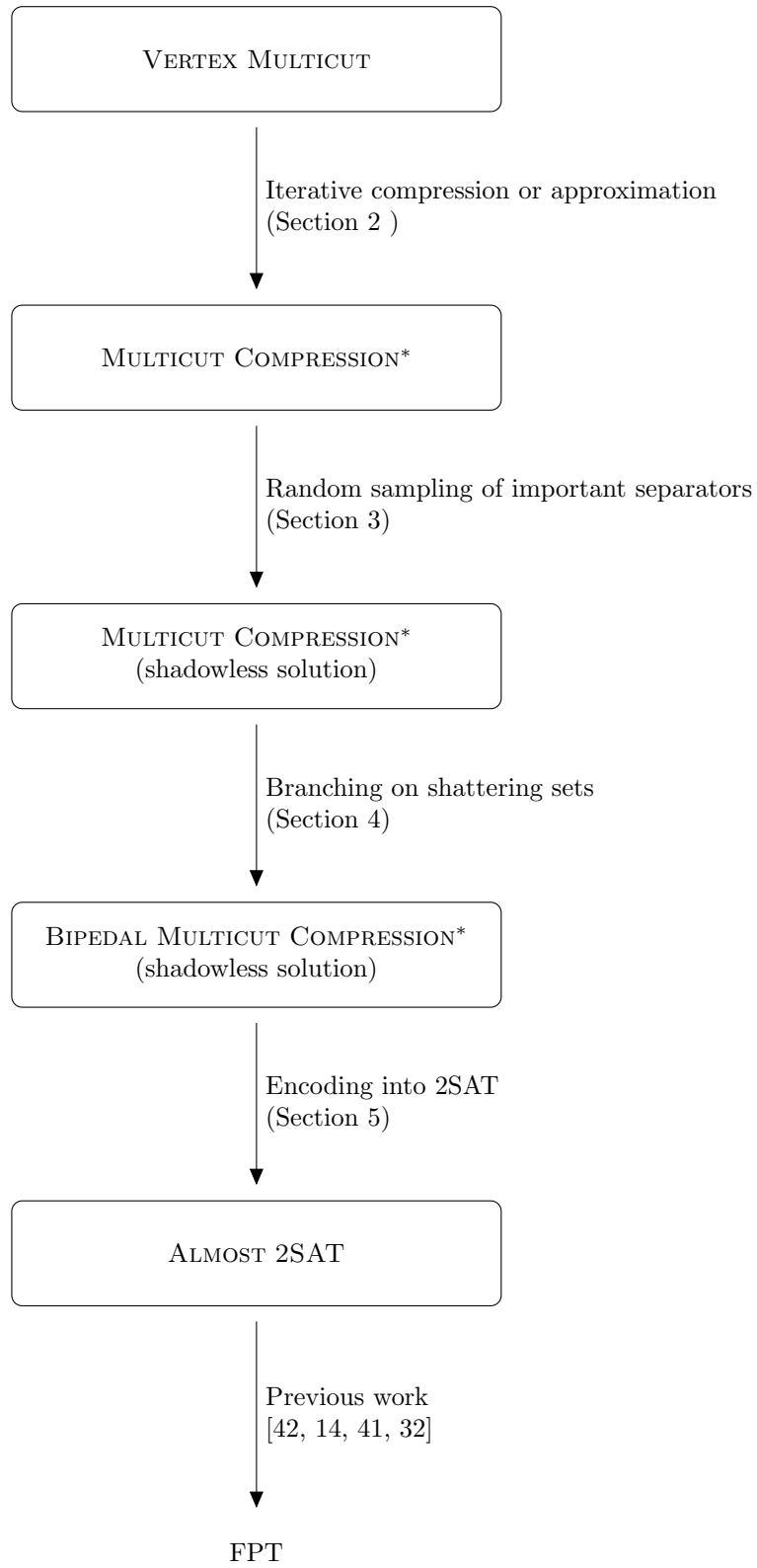

Figure 1: The chain of reductions in the paper.

Our main technical contribution is showing that MULTICUT COMPRESSION is FPT parameterized by  $p$  and  $|W|$ .

**Lemma 2.1.** MULTICUT COMPRESSION *can be solved in time*  $O^*(2^{O((p+\log|W|)^3+|W|\log|W|)})$ .

Intuitively, it is clear that proving Lemma 2.1 could be easier than proving that VERTEX MULTICUT is FPT: the extra input  $W$  can give us useful structural information about the graph (and as  $|W|$  appears in the running time, a large  $W$  is also helpful). What’s not obvious is how solving MULTICUT COMPRESSION gives us any help in the solution of the original VERTEX MULTICUT problem. We sketch two methods.

**Method 1.** Let us use the polynomial-time approximation algorithm of Gupta [27] to find a multicut  $W$  of size at most  $c \cdot \text{OPT}^2$ , where  $c$  is a universal constant and  $\text{OPT}$  is the minimum size of a multicut. If  $|W| \geq c \cdot p^2$ , then we can safely answer “NO”, as there is no multicut of size at most  $p$ . Otherwise, we run the algorithm of Lemma 2.1 for this set  $W$  to obtain a solution in time  $O^*(2^{O((p+\log|W|)^3)}) = O^*(2^{O(p^3)})$ .

**Method 2.** The standard technique of *iterative compression* [43, 28] allows us to reduce VERTEX MULTICUT to at most  $|V(G)|$  instances of MULTICUT COMPRESSION with  $|W| = p + 1$ . This technique was used for the 2-approximation of EDGE MULTICUT in [36] and its application is analogous in our case. Let  $(G, \mathbf{T}, p)$  be an instance of VERTEX MULTICUT. Suppose that  $V(G) = \{v_1, \dots, v_n\}$ , let  $G_i = G[\{v_1, \dots, v_i\}]$ , and let  $\mathbf{T}_i$  be the subset of  $\mathbf{T}$  containing the pairs with both endpoints in  $G_i$ . One by one, we consider the instances  $(G_i, \mathbf{T}_i, p)$  in ascending order of  $i$ , and for each instance we find a solution  $S_i$  of size at most  $p$ . We start with  $S_0 = \emptyset$ . For some  $i > 0$ , we compute  $S_i$  provided that  $S_{i-1}$  is already known. Observe that  $S_{i-1} \cup \{v_i\}$  is a multicut of size at most  $p + 1$  for  $(G_i, \mathbf{T}_i)$ . Thus we can use the algorithm for MULTICUT COMPRESSION, which either returns a multicut  $S_i$  of  $(G_i, \mathbf{T}_i)$  having size at most  $p$  or returns “NO”. In the first case, we can continue the iteration with  $i + 1$ . In the second case, we know that there is no multicut of size  $p$  for  $(G, \mathbf{T})$  (as there is no such multicut even for  $(G_i, \mathbf{T}_i)$ ), and hence we can return “NO”.

Both methods result in  $O^*(2^{O(p^3)})$  time algorithms. However, we feel it important to mention both approaches, as improvements in Lemma 2.1 might have different effects on the two methods.

It will be convenient to work with a slightly modified version of the compression problem. We say that a set  $S \subseteq V(G)$  is a *multiway cut* of  $W \subseteq V(G)$  if every component of  $G \setminus S$  contains at most one vertex of  $W$ .

MULTICUT COMPRESSION\*

*Input:* A graph  $G$ , an integer  $p$ ,  
a set  $\mathbf{T}$  of pairs of vertices of  $G$ , and  
a multicut  $W$  of  $(G, \mathbf{T})$ .

*Output:* A set  $S$  of size at most  $p$  such that

- (1)  $S$  is multicut of  $(G, \mathbf{T})$ ,
- (2)  $S \cap W = \emptyset$ , and
- (3)  $S$  is a multiway cut of  $W$

or “NO” if no such set  $S$  exists.

That is, MULTICUT COMPRESSION\* has two additional constraints on the solution  $S$ . In Sections 4–5, we prove that this problem is FPT:

**Lemma 2.2.** MULTICUT COMPRESSION\* *can be solved in time*  $O^*(2^{O((p+\log|W|)^3)})$ .

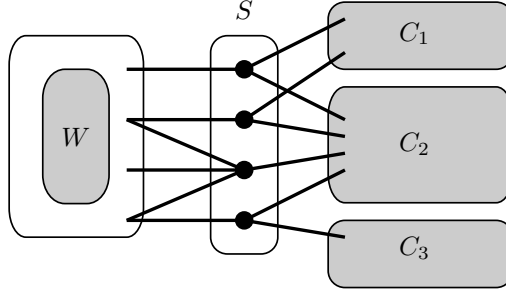

Figure 2: The shadow of  $S$  consists of the three sets  $C_1, C_2, C_3$ .

It is not difficult to reduce MULTICUT COMPRESSION to MULTICUT COMPRESSION\* (an analogous reduction was done in [36] for the edge case). We briefly sketch such a reduction. In order to solve an instance  $(G, \mathbf{T}, W, p)$  of MULTICUT COMPRESSION, we first guess the intersection  $X$  of the multicut  $W$  given in the input and the solution  $S$  we are looking for. This guess results in at most  $\sum_{i=1}^p \binom{|W|}{i}$  branches; in each branch, we remove the vertices of  $X$  from  $G$  and decrease  $p$  by  $|X|$ . Thus in the following, we can restrict our attention to solutions disjoint from  $W$ . Next, we branch on all possible partitions  $(W_1, \dots, W_t)$  of  $W$ , contract each  $W_i$  into a single vertex, and solve MULTICUT COMPRESSION\* on the resulting instance  $(G', \mathbf{T}', W', p')$ . One of the partitions  $(W_1, \dots, W_t)$  corresponds to the way the solution  $S$  partitions  $W$  into connected components, and in this case  $S$  is a multiway cut of  $W'$  in  $G'$ . Thus if the original MULTICUT COMPRESSION instance has a solution  $S$ , then it is a solution of one of the constructed MULTICUT COMPRESSION\* instances. Conversely, any solution of the constructed instances is a solution of the original instance. As the number of partitions of  $W$  can be bounded by  $|W|^{O(|W|)}$ , the running time claimed in Lemma 2.1 follows from Lemma 2.2. Thus in the rest of the paper, it is sufficient to prove Lemma 2.2 to obtain the main result, i.e., Theorem 1.1. Thus proving Lemma 2.2 implies the main result Theorem 1.1.

## 2.2 Shadows

An important step in our algorithm for MULTICUT (and in further applications of the randomized sampling of important separators method) is to argue about solutions that are “shadowless” in the sense defined below. Intuitively, we imagine the vertices in  $W$  as light sources, light spreads on the edges, and  $S$  blocks the light (see Figure 2).

**Definition 2.3.** *Let  $I = (G, \mathbf{T}, W, p)$  be an instance of the MULTICUT COMPRESSION\* problem, and let  $S$  be a solution for  $I$ . The shadow of the set  $S$  is the set of vertices not reachable from any vertex of  $W$  in  $G \setminus S$ . We say that the solution  $S$  is shadowless if the shadow is empty, i.e.,  $G \setminus S$  has exactly  $|W|$  components.*

In Section 3, we present a randomized algorithm that modifies the instance such that if a solution exists, then it makes the solution shadowless with positive probability. The algorithm is based on a randomized contraction of sets defined by “important separators”; we review this concept in Section 3.3. The algorithm can be derandomized to obtain the following lemma:

**Lemma 2.4** (shadowless reduction). *Given an instance  $I$  of the MULTICUT COMPRESSION\* problem, we can construct in time  $O^*(2^{O(p^3)})$  a set of  $t = 2^{O(p^3)} \log n$  instances  $I_1, \dots, I_t$ , each with the same parameter  $p$  as  $I$ , such that*

1. Any solution of  $I_i$  for any  $1 \leq i \leq t$  is a solution of  $I$ .

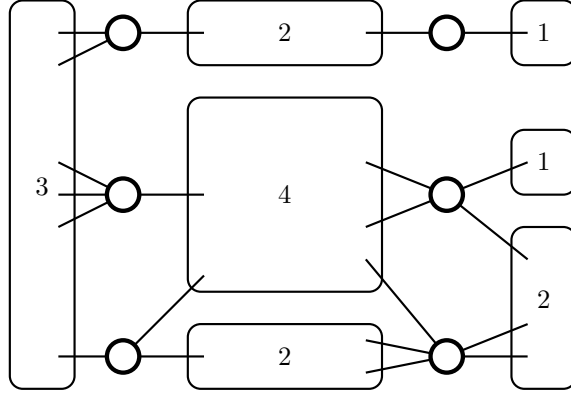

Figure 3: An instance with 7 components. The strong circles are the vertices of  $W$ , the numbers show the number of legs for each component.

2. If  $I$  has a solution, then  $I_i$  has a shadowless solution for at least one  $1 \leq i \leq t$ .

Thus Lemma 2.4 allows us to reduce the MULTICUT COMPRESSION\* problem into a variant where the task is to find a shadowless solution.

### 2.3 Components and legs

In order to find a shadowless solution for a MULTICUT COMPRESSION\* instance, the problem is further transformed in Section 4 using the concept of *legs*.

**Definition 2.5.** *Given an instance  $(G, \mathbf{T}, W, p)$  of MULTICUT COMPRESSION\*, we say that a component  $C$  of  $G \setminus W$  has  $\ell$ -legs if  $C$  is adjacent with  $\ell$  vertices of  $W$  (see Figure 3). We say that a MULTICUT COMPRESSION\* instance is bipedal if every component of  $G \setminus W$  has at most two legs; BIPEDAL MULTICUT COMPRESSION\* is the problem restricted to such instances.*

The transformation presented in Section 4 reduces MULTICUT COMPRESSION\* to a bounded number of bipedal instances.

**Lemma 2.6** (bipedal reduction). *Given an instance  $I$  of the MULTICUT COMPRESSION\* problem with parameter  $p$ , in time  $O^*(2^{O((p+\log|W|)^3)})$  we can either solve this instance or construct a set of  $t = 2^{O(p+\log|W|)^3}$  instances  $I_1, \dots, I_t$ , of BIPEDAL MULTICUT COMPRESSION\* each with parameter at most  $p$ , such that*

1. Any solution of  $I_i$  for any  $1 \leq i \leq t$  is a solution of  $I$ .
2. If  $I$  has a shadowless solution, then  $I_i$  has a shadowless solution for at least one  $1 \leq i \leq t$ .

Finally, in Section 5, we show how this solution can be found by a quite intuitive reduction to an FPT problem ALMOST 2SAT.

**Lemma 2.7.** *Let  $I = (G, \mathbf{T}, W, p)$  be an instance of BIPEDAL MULTICUT COMPRESSION\* that has a shadowless solution  $S$  of size at most  $p$ . In time  $O^*(4^p)$ , we can find a (not necessarily shadowless) solution  $S'$ .*

Combining Lemmas 2.4–2.7 allows us to prove Lemma 2.2 and therefore to solve VERTEX MULTICUT.



*Proof (of Lemma 2.2).* Let us apply the Algorithm of Lemma 2.4 to an instance  $I = (G, \mathbf{T}, W, p)$  of MULTICUT COMPRESSION\*. This algorithm takes time  $O^*(2^{O(p^3)})$  and produces  $t = 2^{O(p^3)} \log n$  instances  $I_i$  of the MULTICUT COMPRESSION\* problem, each with parameter at most  $p$ , so that the original instance  $I$  has a solution if and only if one of these  $t$  instances has a *shadowless* solution. Moreover a (not necessarily shadowless) solution of any of these instances is also a solution of the original instance.

Apply to each instance  $I_i$  the algorithm of Lemma 2.6, which in time  $O^*(2^{O((p+\log|W|)^3)})$  either returns an answer or produces  $2^{O((p+\log|W|)^3)}$  instances  $I_{i,j}$ , each with parameter at most  $p$ , of the BIPEDAL MULTICUT COMPRESSION\* problem such that  $I_i$  has a shadowless solution if and only if at least one  $I_{i,j}$  has a shadowless solution. Moreover a (not necessarily shadowless) solution of any new instance  $I_{i,j}$  is also a solution of  $I_i$ .

Combining the above two steps, we conclude that in time  $O^*(2^{O((p+\log|W|)^3)})$  the algorithm produces  $2^{O((p+\log|W|)^3)} \log n$  instances of the BIPEDAL MULTICUT COMPRESSION\* problem such that the original instance  $I$  has a solution if and only if at least one of the these  $2^{O((p+\log|W|)^3)} \log n$  instances has a shadowless solution. Moreover a (not necessarily shadowless) solution of any instance  $I_{i,j}$  is also a solution of  $I$ .

Finally, we apply to each resulting instance  $I_{i,j}$  of the BIPEDAL MULTICUT COMPRESSION\* problem the algorithm of Lemma 2.7. By the discussion above, if the algorithm returns a solution for at least one of the instances, then this is a solution of the original instance  $I$ . If the algorithm returns “NO” for all the instances, this means that no one of them has a shadowless solution. It follows that the original instance does not have a solution either. Taking into account that the algorithm of Lemma 2.7 takes time  $O^*(4^p)$ , processing of  $2^{O((p+\log|W|)^3)} \log n$  instances takes time  $O^*(2^{O((p+\log|W|)^3)})$ . Consequently, the instance  $I$  of the MULTICUT COMPRESSION\* problem can be solved in time  $O^*(2^{O((p+\log|W|)^3)})$ .  $\square$

### 3 Making the solution shadowless

The purpose of this section is to reduce solving MULTICUT COMPRESSION\* to finding a shadowless solution. We present a randomized transformation that, given an instance having a solution, modifies the instance in such a way that the new instance has a *shadowless* solution with probability  $2^{-O(p^3)}$ . More precisely:

**Lemma 3.1.** *Given an instance  $I$  of the MULTICUT COMPRESSION\* problem, we can construct in time  $O^*(2^{O(p)})$  an instance  $I'$  with the same parameter  $p$  as  $I$  such that*

1. *Any solution of  $I'$  is a solution of  $I$ .*
2. *If  $I$  has a solution, then  $I'$  has a shadowless solution with probability  $2^{-O(p^3)}$ .*

This means that if  $I$  has a solution, then by invoking Lemma 3.1  $2^{O(p^3)}$  times, with constant probability at least one of the instances has a shadowless solution. Thus if we are able to solve the problem with the assumption that a shadowless solution exists, then this way we can get a solution for  $I$  with constant probability. The main result of this section is a derandomized version of this transformation (Lemma 2.4).

The main idea in the proof of Lemma 3.1 is to try to randomly guess a set  $Z$  whose removal does not change the instance substantially, but makes the instance shadowless. Section 3.1 introduces the torso operation, which is used to remove the set  $Z$ , and states what properties the set  $Z$  needs to satisfy. The construction of  $Z$  is based on the observation that the solution can be characterized by a “closest set” and we need to locate the boundary of such a set (Section 3.2). We develop a randomized algorithm for this purpose in Sections 3.3–3.6. The algorithm uses the notion of

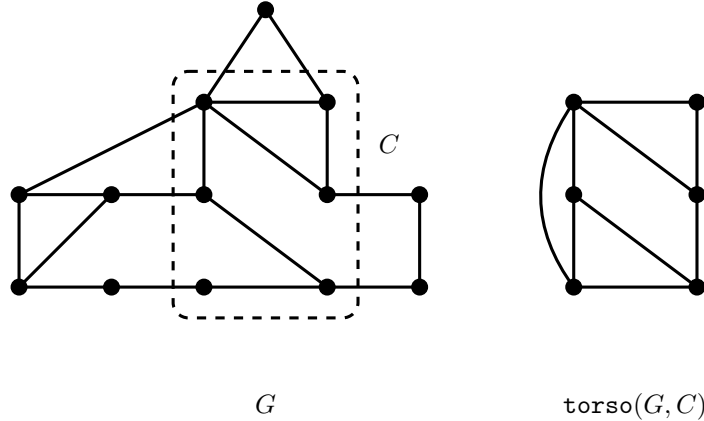

Figure 4: The torso operation on the graph  $G$  with a set  $C$  of 6 vertices.

important separators; Section 3.3 reviews this concept and shows why it is relevant for our problem. Sections 3.4–3.5 describe and analyze the randomized selection process. Section 3.6 shows how the random selection can be derandomized to obtain the deterministic version, Lemma 2.4.

### 3.1 Torsos and shadowless solutions

The randomized transformation can be conveniently described using the operation of taking the *torso* of a graph.

**Definition 3.2.** *Let  $G$  be a graph and  $C \subseteq V(G)$ . The graph  $\text{torso}(G, C)$  has vertex set  $C$  and two vertices  $a, b \in C$  are adjacent if  $\{a, b\} \in E(G)$  or there is a path  $P$  in  $G$  connecting  $a$  and  $b$  whose internal vertices are not in  $C$ .*

In particular, every edge of  $G[C]$  is in  $\text{torso}(G, C)$ . It is easy to show that this operation preserves separation inside  $C$ :

**Proposition 3.3.** *Let  $C \subseteq V(G)$  be a set of vertices in  $G$  and let  $a, b \in C$  two vertices. A set  $S \subseteq C$  separates vertices  $a$  and  $b$  in  $\text{torso}(G, C)$  if and only if  $S$  separates these vertices in  $G$ .*

*Proof.* Let  $P$  be a path connecting  $a$  and  $b$  in  $G$  and suppose that  $P$  is disjoint from the set  $S$ . The path  $P$  contains vertices from  $C$  and from  $V(G) \setminus C$ . If  $u, v \in C$  are two vertices such that every vertex of  $P$  between  $u$  and  $v$  is from  $V(G) \setminus C$ , then by definition there is an edge  $uv$  in  $\text{torso}(G, C)$ . Using these edges, we can modify  $P$  to obtain a path  $P'$  that connects  $a$  and  $b$  in  $\text{torso}(G, C)$  and avoids  $S$ .

Conversely, suppose that  $P$  is a path connecting  $a$  and  $b$  in the graph  $\text{torso}(G, C)$  and it avoids  $S \subseteq C$ . If  $P$  uses an edge  $uv$  that is not present in  $G$ , then this means that there is a path connecting  $u$  and  $v$  whose internal vertices are not in  $C$ . Using these paths, we can modify  $P$  to obtain a path  $P'$  that uses only the edges of  $G$ . Since  $S \subseteq C$ , the new vertices on the path are not in  $S$ , i.e.,  $P'$  avoids  $S$  as well.  $\square$

Let  $I = (G, W, \mathbf{T}, p)$  be an arbitrary instance of MULTICUT COMPRESSION\*. Given a set  $Z \subseteq V(G) \setminus W$  of vertices, the *reduced instance*  $I/Z = (G', W, \mathbf{T}', p)$  is defined the following way:

1. The graph  $G'$  is  $\text{torso}(G, V(G) \setminus Z)$ .

2. For every  $v \in V(G)$ , let  $\phi(v) = N(C)$  if  $v$  belongs to component  $C$  of  $G[Z]$ , and let  $\phi(v) = \{v\}$  if  $v \notin Z$ . The set  $\mathbf{T}'$  is obtained by replacing every pair  $(x, y) \in \mathbf{T}$  with the set of pairs  $\{(x', y') \mid x' \in \phi(x), y' \in \phi(y)\}$ .

The main observation is that if we perform this torso operation for a  $Z$  that is sufficiently large to cover the shadow of a hypothetical solution  $S$  and sufficiently small to be disjoint from  $S$ , then  $S$  becomes a shadowless solution of  $I/Z$ . Furthermore, the torso operation is “safe” in the sense that it does not make the problem easier, i.e., does not create new solutions.

**Lemma 3.4.** *Let  $I = (G, \mathbf{T}, W, p)$  be an instance of MULTICUT COMPRESSION\* and let  $Z \subseteq V(G) \setminus W$  be a set of vertices.*

- (1) *Every solution of  $I/Z$  is a solution of  $I$ .*
- (2) *If  $I$  has a solution  $S$  such that  $Z$  covers the shadow and  $Z \cap S = \emptyset$ , then  $S$  is a shadowless solution of  $I/Z$ .*

*Proof.* Let  $G$  and  $G' = \text{torso}(G, V(G) \setminus Z)$  be the graphs in instances  $I$  and  $I/Z$ , respectively. To prove the first statement, we show that if  $S' \subseteq V(G')$  is a solution of  $I/Z$ , then  $S'$  is a solution of  $I$  as well. Suppose that some pair  $(x, y)$  of  $I$  is not separated by  $S'$ . Let  $P$  be a path in  $G \setminus S'$  going from  $x$  to  $y$ . Let  $x'$  and  $y'$  be the first and last vertex of  $P$  not in  $Z$ , respectively, and let  $P'$  be the subpath of  $P$  from  $x'$  to  $y'$ . (Note that  $P$  cannot be fully contained in  $Z$ , as it contains at least one vertex of the multicut  $W$ .) By the way  $I/Z$  is defined,  $(x', y')$  is a pair in  $I/Z$ , hence  $S'$  separates  $x'$  and  $y'$  in  $G' = \text{torso}(G, C)$ . Using Prop. 3.3 with  $C = V(G) \setminus Z$ , we get that  $S'$  separates  $x'$  and  $y'$  in  $G$ , which is in contradiction with the existence of the path  $P$ . A similar argument shows that there is no path in  $G \setminus S'$  that connects two vertices of  $W$ .

For the second statement, suppose that  $S$  is a solution of  $I$  with  $S \cap Z = \emptyset$ . Let us show that  $S$  is a solution of  $I/Z$  as well. Suppose that  $S$  does not separate  $x'$  and  $y'$  in  $G'$  for some pair  $(x', y')$  of  $I/Z$ . Using Prop. 3.3 with  $C = V(G) \setminus Z$ , we get that  $S'$  does not separate  $x'$  and  $y'$  in  $G$ , i.e., there is an  $x' - y'$  path  $P$  in  $G \setminus S$ . By the way the pairs in  $I/Z$  were defined, there is a pair  $(x, y)$  of  $I$  and there is an  $x - x'$  path  $P_1$  such that  $x'$  is the only vertex of  $P_1$  not in  $Z$ , and there is a  $y - y'$  path  $P_2$  such that  $y'$  is the only vertex of  $P_2$  not in  $Z$ . Clearly, these paths are disjoint from  $S$ . Therefore, the concatenation of  $P_1, P, P_2$  is an  $x - y$  path in  $G \setminus S$ , contradicting that  $S$  is a solution of  $I$ .

To see that  $S$  is shadowless in  $G'$ , consider a vertex  $v$  of  $G' \setminus S$ . As  $v \notin Z$  is not in the shadow of the solution  $S$  of  $I$ , there is a path  $P$  in  $G \setminus S$  going from  $v$  to a vertex  $w \in W$ . Again by Prop. 3.3, this means that there is a  $v - w$  path in  $G' \setminus S$  as well, which means that  $v$  is not in the shadow of the solution  $S$  of  $I'$ .  $\square$

## 3.2 Closest sets

Lemma 3.4 shows that in order to reduce the MULTICUT COMPRESSION\* problem to finding a shadowless solution, all we need is a set  $Z$  that covers the shadow of a hypothetical solution  $S$ , but disjoint from  $S$  itself. It is not obvious how this observation is of any help: it seems that there is no way of constructing such a set without actually knowing a solution  $S$ . Nevertheless, we present a randomized procedure that constructs such a set with non-negligible probability.

The main idea of the randomized procedure is that a solution of a MULTICUT COMPRESSION\* instance can be characterized by the set of vertices reachable from  $W$ , and we can assume that this set has the property that it cannot be made smaller without increasing the size of the boundary. The following definition formalizes this property:

**Definition 3.5.** Let  $G$  be an undirected graph and let  $W \subseteq V(G)$  be a subset of vertices. We say that a set  $R \supseteq W$  is a  $W$ -closest set if there is no  $R' \subset R$  with  $R' \supseteq W$  and  $|N(R')| \leq |N(R)|$ .

The main technical idea of the paper is the following randomized procedure, which, in some sense, finds the boundary of a closest set. Note that this statement could be of independent interest, as it is about closest sets in general and contains nothing specific to multicut problems.

**Theorem 3.6** (random sampling). *There is a randomized algorithm  $\text{RandomSet}(G, W, p)$  that, given a graph  $G$ , a set  $W \subseteq V(G)$ , and an integer  $p$ , produces a set  $Z \subseteq V(G) \setminus W$  such that the following holds. For every  $W$ -closest set  $R$  with  $|N(R)| \leq p$ , the probability that the following two events both occur is at least  $2^{-O(p^3)}$ :*

1.  $N(R) \cap Z = \emptyset$ , and
2.  $V(G) \setminus (R \cup N(R)) \subseteq Z$ .

That is, the two events say that  $Z$  covers every vertex outside  $R \cup N(R)$  and may cover some vertices inside  $R$ , but disjoint from  $N(R)$ . To prove Theorem 3.6, we introduce the main new technique of the paper: random sampling of important separators. In Section 3.3, we review the notion of important separators. Section 3.4 contains a simplified proof of Theorem 3.6 (with probability bound  $2^{-2^{O(p)}}$  instead of  $2^{-O(p^3)}$ ). The full proof appears in Section 3.5. We show below that Theorem 3.6 can be used to prove Lemma 3.1. Section 3.6 shows how to derandomize Theorem 3.6, which immediately proves Lemma 2.4.

*Proof (of Lemma 3.1).* Let  $I = (G, W, \mathbf{T}, p)$  be an instance of  $\text{MULTICUT COMPRESSION}^*$ . Let us use the algorithm  $\text{RandomSet}(G, W, p)$  of Theorem 3.6 to obtain a set  $Z$  and let  $I' = I/Z$ . By Lemma 3.4, every solution of  $I'$  is a solution of  $I$  as well.

Assume now that  $I$  has a solution  $S$ ; let  $S$  be a solution such that  $|S|$  is minimum possible, and among such solutions the set  $R$  of vertices reachable from  $W$  in  $G \setminus S$  is as small as possible. Clearly,  $N(R) \subseteq S$ . We claim that  $R$  is a  $W$ -closest set. Suppose that there is a set  $R' \subset R$  containing  $W$  such that  $|N(R')| \leq |N(R)|$ . Let  $S' = N(R')$ , we have that  $|S'| \leq |S|$ . We claim that  $S'$  is a solution, contradicting the minimality of  $S$ . Suppose that there is a path  $P$  in  $G \setminus S'$  connecting the two terminals in a pair  $(x, y) \in \mathbf{T}$  or two vertices of  $W$ . In both cases,  $P$  has to go through a vertex of  $W$  (here we use that the definition of  $\text{MULTICUT COMPRESSION}^*$  requires that  $W$  is a multicut). Therefore,  $P$  is fully contained in  $R' \subset R$ , which implies that it is disjoint from  $N(R) \subseteq S$ , i.e.,  $S$  is not a solution. Thus  $S'$  is indeed a solution with  $|S'| \leq |S|$  and  $|R'| < |R|$ , contradicting the choice of the solution  $S$ . This contradiction proves our claim that  $R$  is a  $W$ -closest set. The same argument shows that  $N(R)$  is a solution, hence  $S = N(R)$  has to hold.

As  $R$  is a  $W$ -closest set, the probability that both  $S \cap Z = \emptyset$  and  $V(G) \setminus (R \cup S) \subseteq Z$  hold is  $2^{-O(p^3)}$ . The later inclusion is equivalent to saying that the shadow of the solution  $S$  is contained in  $Z$ . Therefore, by Lemma 3.4, set  $S$  is a shadowless solution of instance  $I'$ .  $\square$

### 3.3 Important separators

The concept of important separators was introduced in [35] to deal with the multiway cut problem.

**Definition 3.7.** Let  $G$  be an undirected graph and let  $X, Y \subseteq V(G)$  be two disjoint sets. A set  $S \subseteq V(G)$  of vertices is an  $X - Y$  separator if  $S$  is disjoint from  $X \cup Y$  and there is no component  $K$  of  $G \setminus S$  with both  $K \cap X \neq \emptyset$  and  $K \cap Y \neq \emptyset$ .

In other words,  $G \setminus S$  contains no path between  $X$  and  $Y$ . To improve readability, we write  $s - Y$  separator instead of  $\{s\} - Y$  separator if  $s$  is a single vertex. We emphasize the fact that, by our definition, an  $X - Y$  separator is disjoint from  $X$  and  $Y$ .

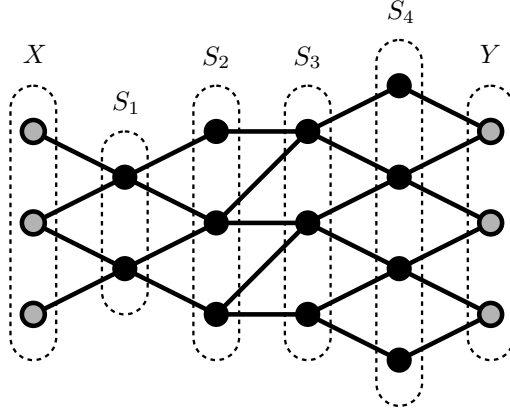

Figure 5: Set  $S_1$  is the unique minimum  $X - Y$  separator and therefore it is an important  $X - Y$  separator. Set  $S_2$  is not an important  $X - Y$  separator, as  $|S_2| = |S_3|$  and a superset of vertices is reachable from  $X$  in  $G \setminus S_3$  compared to  $G \setminus S_2$ . Sets  $S_3$  and  $S_4$  are both important  $X - Y$  separators.

**Definition 3.8.** Let  $X, Y \subseteq V(G)$  be disjoint sets of vertices,  $S \subseteq V(G)$  be an  $X - Y$  separator, and let  $K$  be the union of every component of  $G \setminus S$  intersecting  $X$ . We say that  $S$  is an important  $X - Y$  separator if it is inclusionwise minimal and there is no  $X - Y$  separator  $S'$  with  $|S'| \leq |S|$  such that  $K' \supset K$ , where  $K'$  is the union of every component of  $G \setminus S'$  intersecting  $X$ .

See Figure 5 for illustration. Note that the order of  $X$  and  $Y$  matters: an important  $X - Y$  separator is not necessarily an important  $Y - X$  separator. It is easy to see that if  $S$  is an important  $X - Y$  separator, then  $S = N(R)$  for some set  $R$  with  $X \subseteq R$  and  $(R \cup N(R)) \cap Y = \emptyset$ : we can define  $R$  to be the set of vertices reachable from  $X$  in  $G \setminus S$ . Observe that if  $R$  is defined this way, then every component of  $G[R]$  contains at least one vertex of  $X$ . In particular, if  $X$  contains only a single vertex, then we can assume that  $G[R]$  is connected.

A bound on the number of important separators was given in [35] (although the notation there is slightly different). A better bound is implicit in [8]. For the convenience of the reader, we give a self-contained proof of the following fact in the appendix.

**Lemma 3.9.** Let  $X, Y \subseteq V(G)$  be disjoint sets of vertices in a graph  $G$ . For every  $p \geq 0$ , there are at most  $4^p$  important  $X - Y$  separators of size at most  $p$ . Furthermore, we can enumerate all these separators in time  $4^p \cdot p \cdot (|E(G)| + |V(G)|)$ .

Note that one can give an exponential lower bound on the number of important separators as a function of  $p$  and in fact the bound  $4^p$  in Lemma 3.9 is asymptotically tight up to factors polynomial in  $p$ .

The following lemma connects closest sets and important separators by showing that the boundary of a closest set is formed by important separators. Intuitively, every vertex  $v$  outside the closest set  $R$  “sees” a part of the boundary  $N(R)$  that is an important  $v - W$  separator: otherwise, we could “push” this part of the boundary away from  $v$  and towards  $W$ , contradicting the assumption that  $R$  is a closest set.

**Lemma 3.10** (pushing). Let  $G$  be an undirected graph,  $W$  a set of vertices, and  $R$  a  $W$ -closest set. For every vertex  $v \notin R \cup N(R)$ , there is an important  $v - W$  separator  $S_v \subseteq N(R)$ .

*Proof.* Let  $v$  be an arbitrary vertex of  $G$  not in  $R \cup N(R)$  and let  $K$  be the component of  $G \setminus N(R)$  containing  $v$ . As  $v \notin R \cup N(R)$  and  $W \subseteq R$ , we have that  $K$  is disjoint from  $W$ . We show that

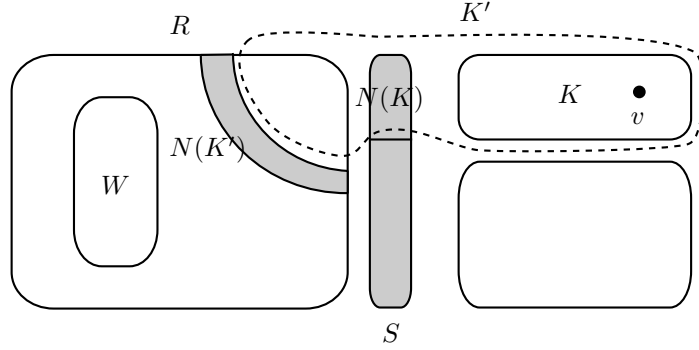

Figure 6: Proof of Lemma 3.10. Note that, in general,  $K'$  can intersect other components of  $G \setminus (R \cup N(R))$ .

$N(K)$  is an important  $v - W$  separator. First, we observe that  $N(K)$  is a minimal  $v - W$  separator: we have  $N(K) \subseteq N(R)$ , thus every vertex of  $N(K)$  is adjacent to both  $K$  and  $R$ . Thus, if  $N(K)$  is not an important  $v - W$  separator, then there is a  $K' \supset K$  such that  $K' \cup N(K')$  is disjoint from  $W$  and  $|N(K')| \leq |N(K)|$ . We may assume that  $G[K']$  is connected. Let  $R' := R \setminus (K' \cup N(K'))$ . Now  $N(R') \subseteq (N(R) \setminus N(K)) \cup N(K')$ : it is clear that every neighbor of  $R'$  is in  $N(R) \cup N(K')$  (as it cannot be in  $K'$ ) and every vertex of  $N(K) \setminus N(K')$  is fully contained in  $K'$ . Thus  $|N(R')| \leq |N(R)|$  follows from  $|N(K')| \leq |N(K)|$ . Furthermore, the connectivity of  $G[K']$  and  $K \subset K'$  implies that  $K'$  contains a vertex of  $N(K) \subseteq N(R)$  and therefore  $K' \cup N(K')$  contains a vertex of  $R$ . This means that  $R$  is a proper subset of  $R'$  with  $|N(R')| \leq |N(R)|$ , contradicting the assumption that  $R$  is a  $W$ -closest set.  $\square$

### 3.4 Random sampling of important separators—simplified proof

In this section, we present a simpler version of the proof of Theorem 3.6, where the probability of success is double exponentially small in  $p$ . This simpler proof highlights the main idea of the randomized reduction. The full proof, which improves the probability to  $2^{-O(p^3)}$  with additional ideas, appears in Section 3.5.

By Lemma 3.9 we can enumerate every separator of size at most  $p$  that is an important  $v - W$  separator for some  $v$ .

**Definition 3.11.** *The set  $\mathcal{I}_p$  contains a set  $S \subseteq V(G) \setminus W$  if  $S$  is an important  $v - W$  separator of size at most  $p$  for some vertex  $v \in V(G) \setminus (W \cup S)$ .*

By Lemma 3.9, the size of  $\mathcal{I}_p$  is at most  $4^p \cdot |V(G)|$  and we can construct  $\mathcal{I}_p$  in time  $O^*(4^p)$ .

Recall that the shadow of a set  $S$  is the set of vertices not reachable from  $W$  in  $G \setminus S$ . By Lemma 3.10, every vertex of the shadow of  $N(R)$  is covered by the shadow of a member of  $\mathcal{I}_p$  that is a subset of  $N(R)$ . This means that the shadow of  $2^p$  members of  $\mathcal{I}_p$  fully cover the shadow of  $N(R)$ . This suggests that we may construct a set  $Z$  satisfying the conditions of Theorem 3.6 by guessing these members of  $\mathcal{I}_p$  and obtaining  $Z$  as the union of the shadows of the selected sets. However, in general the size of  $\mathcal{I}_p$  cannot be bounded as a function of  $p$  only. Thus complete enumeration of all possible ways of selecting  $2^p$  members of  $\mathcal{I}_p$  is not feasible. Instead, we randomly select a subset of  $\mathcal{I}_p$  and hope that it contains these at most  $2^p$  members and it does not contain any member of  $\mathcal{I}_p$  whose shadow intersects  $N(R)$ .

The probability of randomly selecting a member of  $\mathcal{I}_p$  should not be too high, because we want to avoid selecting any member whose shadow contains a vertex of  $N(R)$ . We need a bound on the

number such members of  $\mathcal{I}_p$ . Intuitively, the bound of Lemma 3.9 on the number of important separators should imply that each vertex of  $N(R)$  is contained in the shadow of a bounded number of members of  $\mathcal{I}_p$ , but in order to make this claim precise, we need to consider a slightly different notion of a shadow:

**Definition 3.12.** *The exact shadow of a set  $S \subseteq V(G) \setminus W$  contains those vertices  $v \in V(G) \setminus (W \cup S)$  for which  $S$  is a minimal  $v - W$  separator.*

For example, in Figure 2, set  $C_2$  is in the exact shadow of  $S$ , but  $C_1$  is not, as a 2-vertex subset of  $S$  separates every vertex of  $C_1$  from  $W$ .

The following lemma is true only for exact shadows: the bound in (2) is not true with the original definition of shadow.

**Lemma 3.13.** (1) *For every  $S \in \mathcal{I}_p$ , we have that  $v \in V(G) \setminus (W \cup S)$  is in the exact shadow of  $S$  if and only if  $S$  is an important  $v - W$  separator.*

(2) *Each vertex  $v \in V(G) \setminus W$  is contained in the exact shadow of at most  $4^p$  members of  $\mathcal{I}_p$ .*

*Proof.* (1) By definition, if  $S$  is an important  $v - W$  separator, then  $S$  is a minimal  $v - W$  separator, hence  $v$  is in the exact shadow of  $S$ . For the other direction, suppose that  $v$  is in the exact shadow of some  $S \in \mathcal{I}_p$ . By definition of  $\mathcal{I}_p$ , there is a vertex  $u \in V(G) \setminus (W \cup S)$  such that  $S$  is an important  $u - W$  separator. If  $S$  is not an important  $v - W$  separator, then (as the definition of exact shadow implies that  $S$  is a minimal  $v - W$  separator) there is a  $v - W$  separator  $S'$  with  $|S'| \leq |S|$  and such that a superset of vertices is reachable from  $v$  in  $G \setminus S'$  compared to  $G \setminus S$ .

We claim that  $S'$  is a  $u - W$  separator as well. Suppose that there is a  $u - W$  path  $P$  in  $G \setminus S'$ . This path has to go through  $S \setminus S'$ ; let  $s$  be the first vertex of  $S \setminus S'$  on  $P$  when going from  $u$  to  $W$ . Since  $S$  is a minimal  $v - W$  separator,  $s$  has a neighbor reachable from  $v$  in  $G \setminus S$  and hence in  $G \setminus S'$ . Therefore,  $s \notin S'$  is also reachable from  $v$  in  $G \setminus S'$ . It follows that  $s$  is reachable from both  $u$  and  $v$  in  $G \setminus S'$ , i.e.,  $u$  and  $v$  are in the same component of  $G \setminus S'$ , contradicting the assumption that  $S'$  is a  $v - W$  separator.

Next we show that every vertex  $r$  reachable from  $u$  in  $G \setminus S$  is reachable from  $u$  in  $G \setminus S'$ . Let  $P$  be an  $u - r$  path in  $G \setminus S$  and suppose that it contains a vertex  $q \in S' \setminus S$ . As  $S'$  is a minimal  $v - W$  separator, there is a  $q - W$  path  $Q$  that intersects  $S'$  only in  $q$ . The concatenation of the prefix of  $P$  ending at  $q$  and  $Q$  is a  $u - W$  walk, hence  $Q$  has to contain a vertex  $q' \in S$ . Vertex  $q$  cannot be on  $P$ ; in particular,  $q' \neq q$ . By the definition of  $Q$ , this vertex  $q'$  has to be in  $S \setminus S'$  and hence it is reachable from  $v$  in  $G \setminus S'$ . However, the subpath of  $Q$  from  $q'$  to  $W$  does not contain any vertex of  $S'$ , meaning that  $v$  is reachable also from  $W$  in  $G \setminus S'$ , a contradiction. This shows that every vertex reachable from  $u$  in  $G \setminus S$  remains reachable in  $G \setminus S'$ , contradicting the assumption that  $S$  is an important  $u - W$  separator. Therefore,  $S$  is indeed an important  $v - W$  separator.

(2) By Lemma 3.9, there are at most  $4^p$  important  $v - W$  separators of size at most  $p$ , thus by (1), vertex  $v$  can be contained in the exact shadows of at most that many members of  $\mathcal{I}_p$ .  $\square$

Combining Lemmas 3.10 and 3.13, we immediately have:

**Proposition 3.14.** *Let  $R$  be a  $W$ -closest set and let  $S = N(R)$ . Then every vertex  $v \notin R \cup N(R)$  is in the exact shadow of an some  $S_v \in \mathcal{I}_p$  with  $S_v \subseteq S$ .*

We use Prop. 3.14 to bound the probability that the constructed set  $Z$  satisfies the second condition of Theorem 3.6. We need the following simple observation to argue that the selection of these sets does not interfere with the first condition of Theorem 3.6.

**Lemma 3.15.** *Let  $R$  be a  $W$ -closest set and let  $S = N(R)$  and  $S' \subseteq S$ . Then the shadow of  $S'$  is disjoint from  $S$ .*

*Proof.* Suppose that  $v \in S$  is in the shadow of  $S' \subseteq S$ , i.e.,  $v \notin S'$  and  $S'$  is a  $v - W$  separator. As  $v \in N(R)$ , vertex  $v$  has a neighbor  $r \in R$ . We can assume that every component of  $G[R]$  contains a vertex of  $W$ : otherwise removing a component disjoint from  $W$  strictly decreases  $R$  without increasing  $|N(R)|$ , contradicting the assumption that  $R$  is a  $W$ -closest set. This means that there is a path from  $r$  to  $W$  fully contained in  $R$ . It follows that there is a path from  $v$  to  $W$  fully contained in  $R \cup \{v\}$ , which is disjoint from  $S'$ , contradicting the assumption that  $v$  is in the shadow of  $S'$ .  $\square$

In the simplified proof of Theorem 3.6, we select members of  $\mathcal{I}_p$  uniformly at random and take the union of their exact shadows. In light of Lemmas 3.10 and 3.13, there is a set of at most  $2^p$  members of  $\mathcal{I}_p$  that have to be selected and there is a set of at most  $N(R) \cdot 4^p$  members of  $\mathcal{I}_p$  that have to be avoided in order for the random selection to be successful.

*Simplified proof of Theorem 3.6.* The algorithm  $\text{RandomSet}(G, W, p)$  first constructs the set  $\mathcal{I}_p$ ; by Lemma 3.9, the size of  $\mathcal{I}_p$  is  $O^*(4^p)$  and can be constructed in time  $O^*(4^p)$ . Let  $\mathcal{I}'_p$  be the subset of  $\mathcal{I}_p$  where each element from  $\mathcal{I}_p$  occurs with probability  $\frac{1}{2}$  independently at random. Let  $Z$  be the union of the exact shadows of every set in  $\mathcal{I}'_p$ . We claim that the set  $Z$  satisfies the requirement of the theorem.

Let  $R$  be a  $W$ -closest set and let  $S = N(R)$ . Let  $X_1, X_2, \dots, X_d \in \mathcal{I}_p$  be the members of  $\mathcal{I}_p$  that are fully contained in  $S$ . As  $|S| \leq p$ , we have  $d \leq 2^p$ . By Lemma 3.15, we have that the exact shadow of  $X_j$  is disjoint from  $S$  for every  $j \in [d]$ . Now consider the following events:

- (E1)  $Z \cap S = \emptyset$
- (E2) the exact shadow of  $X_j$  is a subset of  $Z$  for every  $j \in [d]$ .

Note that by Prop. 3.14, event (E2) implies that the shadow of  $S$  is fully contained in  $Z$ , i.e.,  $V(G) \setminus (R \cup N(R)) \subseteq Z$ . Our goal is to show that with probability  $2^{-2^{O(p)}}$ , events (E1) and (E2) both occur.

Let  $A = \{X_1, X_2, \dots, X_d\}$  and let  $B$  contain those sets in  $\mathcal{I}_p$  whose exact shadows intersect  $S$ . By Lemma 3.13, each vertex of  $S$  is contained in the exact shadow of at most  $4^p$  members of  $\mathcal{I}_p$ . Thus  $|B| \leq |S| \cdot 4^p \leq p \cdot 4^p$ . If no member of  $B$  is selected into  $\mathcal{I}'_p$ , then event (E1) occurs. If every member of  $A$  is selected into  $\mathcal{I}'_p$ , then event (E2) occurs. Thus the probability that both (E1) and (E2) occur is bounded from below by the probability of the event that every element from  $A$  is selected and no element from  $B$  is selected. Note that  $A$  and  $B$  are disjoint:  $A$  contains only sets whose exact shadows are disjoint from  $S$ , while  $B$  contains only sets whose exact shadows intersect  $S$ . Therefore, the two events are independent and the probability that both events occur is at least

$$\left(\frac{1}{2}\right)^{2^p} \left(1 - \frac{1}{2}\right)^{p \cdot 4^p} = 2^{-2^{O(p)}}$$

$\square$

### 3.5 Random sampling of important separators—full proof

In order to optimize the success probability, we perform the randomized selection of important separators in two phases: first we select some members of  $\mathcal{I}_p$  and add new edges to the graph and in the second phase we restrict our attention to members of  $\mathcal{I}_p$  that induce cliques in the modified graph. We observe that important separators that induce cliques are nested, hence we can get a bound of  $p$  instead of  $4^p$  for the number of such separators.

**Lemma 3.16.** *For every vertex  $v \in V(G) \setminus W$ , there are at most  $p$  important  $v - W$  separators of size at most  $p$  inducing a clique.*



*Proof.* Every minimal  $v - W$  separator arises as  $N(X)$  for some set  $X$  with  $v \in X$  and  $G[X]$  connected. The bound follows from observing that important separators inducing cliques are nested. That is, we show that if  $X_1$  and  $X_2$  are connected sets containing  $v$  such that  $N(X_1)$  and  $N(X_2)$  are important  $v - W$  separators inducing cliques, then either  $X_1 \subset X_2$  or  $X_2 \subset X_1$ .

Suppose that  $X_1 \setminus X_2$  and  $X_2 \setminus X_1$  are both nonempty. If  $X_1 \setminus X_2 \neq \emptyset$  and  $X_1$  is connected, then there is a vertex  $x_1 \in X_1 \cap N(X_2)$ . As  $N(X_2)$  is a clique, every vertex of  $N(X_2)$  is adjacent with  $x_1$ , implying that  $N(X_2) \subseteq X_1 \cup N(X_1)$ . If  $X_2 \setminus X_1 \neq \emptyset$ , then a symmetrical argument shows that  $N(X_1) \subseteq X_2 \cup N(X_2)$ . We claim that  $N(X_1 \cup X_2) \subseteq N(X_1) \cap N(X_2)$  and hence  $|N(X_1 \cup X_2)| \leq |N(X_1)|, |N(X_2)|$ ; as  $X_1 \cup X_2 \supset X_1, X_2$ , this would contradict the assumption that  $X_1$  and  $X_2$  are important components. Consider a vertex  $u \in N(X_1 \cup X_2)$ , which must have a neighbor  $w \in X_1 \cup X_2$ . If  $w \in X_1 \cap X_2$ , then  $u \in N(X_1) \cap N(X_2)$  and we are done. Suppose without loss of generality that  $w \in X_1 \setminus X_2$ . Then  $u \in N(X_1) \subseteq X_2 \cup N(X_2)$ , but  $u \notin X_2$  by definition, hence  $u$  has to be in  $N(X_2)$  as well.

Suppose now that  $X_1, X_2, \dots, X_t$  are connected sets containing  $v$  such that  $N(X_1), N(X_2), \dots, N(X_t)$  are important  $v - W$  separators inducing cliques. We have shown that the  $X_i$ 's form a chain, i.e., we can assume without loss of generality that  $X_1 \subset X_2 \subset \dots \subset X_t$ . This means that there are at most  $p$  of them, as the definition of important separator implies that  $|N(X_1)| < |N(X_2)| < \dots < |N(X_t)|$  has to hold.  $\square$

By Lemma 3.13(1), we have the following the bound:

**Lemma 3.17.** *Every vertex  $v \in V(G) \setminus W$  is contained in the exact shadow of at most  $p$  sets  $X \in \mathcal{I}_p$  such that  $G[N(X)]$  is a clique.*

*Full proof of Theorem 3.6.* The randomized algorithm consists of two phases. For consistency of notation, let  $G_1 = G$  and  $\mathcal{I}_{p,1} = \mathcal{I}_p$ . In the first phase, we select a subset of  $\mathcal{I}_p$  and obtain  $G_2$  for  $G_1$  by making the selected sets cliques. Let  $\mathcal{I}_{p,2}$  be defined as  $\mathcal{I}_{p,1}$ , but for graph  $G_2$ :  $S$  is in  $\mathcal{I}_{p,2}$  if it is an important  $v - W$  separator of size at most  $p$  for some vertex  $v \in V(G_2) \setminus (W \cup S)$  in  $G_2$ . In the second phase, we select a subset of  $\mathcal{I}_p$  inducing cliques in  $G_2$  and obtain  $Z$  as the union of the exact shadows of the selected sets.

**Phase 1.** In the first phase, we select a subset  $\mathcal{I}'_{p,1} \subseteq \mathcal{I}_{p,1}$  by putting every set of  $\mathcal{I}_{p,1}$  into  $\mathcal{I}'_{p,1}$  with probability  $p_1 = 4^{-p}$  independently at random. Then we make every set  $X \in \mathcal{I}'_{p,1}$  a clique; let  $G_2$  be the graph obtained this way.

Let  $R$  be a  $W$ -closest set and let  $S = N(R)$ . By Proposition 3.14, there exists a subcollection  $A_2$  of  $\mathcal{I}_{p,1}$ , all being subsets of  $S$ , such that  $V(G) \setminus (R \cup S)$  is covered by the exact shadows of the sets in  $A_2$ . Let us estimate the probability that the events

- (E1) Every  $S' \in A_2$  induces a clique in  $G_2$ .
- (E2) Every  $S' \in A_2$  has the same exact shadow in  $G_1$  and in  $G_2$ .
- (E3) Every  $S' \in A_2$  is in  $\mathcal{I}_{p,2}$ .

occur.

Let us make a subset  $A_1$  of  $A_2$  such that for every  $S_2 \in A_2$  and  $x, y \in S_2$ , there is a set  $S_1 \in A_1$  with  $x, y \in S_1$ . In other words, the sets in  $A_1$  cover every pair  $\{x, y\}$  of vertices covered by the sets in  $A_2$ . Since there are  $\binom{|S|}{2} \leq \binom{p}{2}$  such pairs, it is clear that there exists a collection  $A_1$  of size at most  $\binom{p}{2}$ . Observe that, by Lemma 3.15, the shadow of every set in  $A_1$  is disjoint from  $S$ .

Let  $B_1$  contain those members of  $\mathcal{I}_{p,1}$  whose exact shadows intersect  $S$ ; by Lemma 3.13, we have  $|B_1| \leq |S| \cdot 4^p \leq p \cdot 4^p$ . We claim that if every member of  $A_1$  is in  $\mathcal{I}'_{p,1}$  and no member of  $B_1$  is in  $\mathcal{I}'_{p,1}$ , then (E1–E3) occur.

Consider an  $S' \in A_2$ . Assuming that every member of  $A_1$  is in  $\mathcal{I}'_{p,1}$ , the set  $G_2[S']$  becomes a clique. This shows (E1).

To show (E2), that is, that  $S' \in A_2$  has the same exact shadows in  $G_1$  and  $G_2$ , we show that a subset  $S' \subseteq S$  is a  $v - W$  separator for some vertex  $v$  in  $G_1$  if and only if it is in  $G_2$ . This shows that  $S'$  is a minimal  $v - W$  separator in  $G_1$  if and only if it is in  $G_2$ , implying the equalities of the exact shadows. One direction is clear, as  $G_1$  is a subset of  $G_2$ . For the other direction, suppose that  $S'$  is not a  $v - W$  separator in  $G_2$ . Let  $K$  be the connected component of  $v$  in  $G_1 \setminus S'$ ; by assumption  $K$  is disjoint from  $W$ . Then there have to be two vertices  $a \in K$  and  $b \notin K \cup S'$  that are adjacent in  $G_2$  but not in  $G_1$ . The reason why  $a$  and  $b$  are adjacent in  $G_2$  is that there is some  $X \in \mathcal{I}'_{p,1}$  with  $a, b \in X$ . As we assumed that no member of  $B_1$  is in  $\mathcal{I}'_{p,1}$ , this means that the exact shadow of  $X$  is disjoint from  $S$  (and hence from  $S'$ ). As  $X \in \mathcal{I}_{p,1}$ , it is an important (hence minimal)  $q - W$  separator for some vertex  $q$  in its exact shadow. This means that there are paths from  $q$  to  $a$  and  $b$  in the exact shadow of  $X$ . Therefore, there is a path  $P$  from  $a$  to  $b$  in  $G_1$  whose internal vertices are in the exact shadow of  $X$ , hence disjoint from  $S'$ . It follows that  $b$  is also in the component  $K$  of  $v$  in  $G_1 \setminus S'$ , a contradiction.

Finally, let us show (E3). As  $S' \in \mathcal{I}_{p,1}$ , it is an important  $v - W$  separator for some vertex  $v$ . Again, let  $K$  be the connected component of  $v$  in  $G_1 \setminus S'$ . By the previous paragraph,  $S'$  is a  $K - W$  separator in  $G_2$ . This implies that  $S'$  is an important  $v - W$  separator in  $G_2$  as well: if there is a separator  $S''$  contradicting that  $S'$  is an important  $v - W$  separator in  $G_2$ , then  $S''$  is a  $v - W$  separator in  $G_1$  as well (as  $G_1$  is a subgraph of  $G_2$ ) and at least one vertex of  $S'$  is reachable from  $v$  in  $G_1 \setminus S''$ , which means that  $S''$  contradicts that  $S'$  is an important  $v - W$  separator in  $G_1$ .

We can conclude that the probability that (E1–E3) occur can be bounded from below by the probability of the event that every set in  $A_1$  is selected and no set from  $B_1$  is selected. As the sets  $A_1$  and  $B_1$  are disjoint (recall that the exact shadow of every member of  $A_1$  is disjoint from  $S$  by Lemma 3.15 while the exact shadow of every member of  $B_1$  intersects  $S$  by definition), this probability is at least

$$(1 - 4^{-p})^{p \cdot 4^p} \cdot (4^{-p})^{p^2} \geq e^{-2p} \cdot 4^{-p^3} = 2^{-O(p^3)}$$

(in the inequality, we use that  $1 + x \geq \exp(x/(1+x))$  for every  $x > -1$  and  $1 - 4^{-p} \geq 1/2$ ).

**Phase 2.**  $\mathcal{I}'_{p,2}$  be a subset of  $\mathcal{I}_{p,2}$  where every  $X \in \mathcal{I}_{p,2}$  with  $G_2[X]$  being a clique appears with probability  $p_2 = 1 - 2^{-p}$  independently at random (and if a set  $X \in \mathcal{I}_{p,2}$  does not induce a clique in  $G_2$ , then it is never selected). Let  $Z$  be the union of the exact shadows of the sets in  $\mathcal{I}'_{p,2}$ .

If (E1–E3) occur, then every set in  $A_2$  is in  $\mathcal{I}_{p,2}$  and they induce cliques in  $G_2$ . If additionally the events

(E4)  $Z \cap S = \emptyset$ , and

(E5)  $A_2 \subseteq \mathcal{I}'_{p,2}$

occur, then every  $v \notin R \cup N(R)$  is in the exact shadow of some  $S' \in \mathcal{I}'_{p,2}$  and  $v \in Z$  follows.

Let us estimate the probability that both (E4) and (E5) hold on condition that (E1–E3) hold. Let  $B_2$  contain those members of  $\mathcal{I}_{p,2}$  (inducing cliques) whose exact shadow in  $G_2$  intersects  $S$ ; we have  $|B_2| \leq p|S| \leq p^2$  (by Lemma 3.17, every vertex of  $S$  is contained in the exact shadow of at most  $p$  members of  $\mathcal{I}_{p,2}$  inducing cliques in  $G_2$ ). If no member of  $B_2$  is selected, then no exact shadow of a set of  $\mathcal{I}'_{p,2}$  contains a vertex of  $S$ , and hence  $Z \cap S = \emptyset$ . Note that  $A_2$  and  $B_2$  are disjoint: by (E2), every  $S' \in A_2$  has the same exact shadow in  $G_1$  and  $G_2$ , therefore the exact shadow of  $S' \in A_2$  is disjoint from  $S$  in  $G_2$  as well. Therefore, the probability that (E4) and (E5) hold can be bounded from below by the probability of the event that every member of  $A_2$  is selected and no member of  $B_2$  is selected, which is at least

$$(2^{-p})^{p^2} \cdot (1 - 2^{-p})^{2p} \geq 2^{-p^3} \cdot e^{-2} 2^{-O(p^3)}$$

(again, we use that  $1 + x \geq \exp(x/(1+x))$  for every  $x > -1$  and  $1 - 2^{-p} \geq 1/2$ ).

Taking into account the probability of success in both phases, we get that for each  $W$ -closest set  $R$ , the set  $Z$  satisfies the requirements with probability  $2^{-O(p^3)}$ .  $\square$

### 3.6 Derandomization

By running  $2^{O(p^3)}$  times the algorithm of Lemma 3.1, we get a collection of instances such that at least one of them satisfies the requirements of Lemma 2.4 with arbitrary large constant probability. To obtain a deterministic version of Lemma 2.4, we derandomize the algorithm of Theorem 3.6 using the standard technique of splitters.

**Lemma 3.18.** *There is an algorithm  $\text{DeterministicSets}(G, W, p)$  that, given a graph  $G$ , a set  $W \subseteq V(G)$ , and an integer  $p$ , produces  $t = 2^{O(p^3)} \log^2 |V(G)|$  subsets  $Z_1, \dots, Z_t$  of  $V(G) \setminus W$  such that the following holds. For every closest set  $R$  with  $|N(R)| \leq p$ , there is at least one  $1 \leq i \leq t$  with*

1.  $N(R) \cap Z_i = \emptyset$ , and
2.  $V(G) \setminus (R \cup N(R)) \subseteq Z_i$ .

*Proof.* An  $(n, r, r^2)$ -splitter is a family of functions from  $[n]$  to  $[r^2]$  such that for any subset  $X \subseteq [n]$  with  $|X| = r$ , one of the functions in the family is injective on  $X$ . Naor, Schulman, and Srinivasan [38] gave an explicit construction of an  $(n, r, r^2)$ -splitter of size  $O(r^6 \log r \log n)$ .

Observe that in the first phase of the algorithm of Theorem 3.6, a random subset of a universe  $\mathcal{I}_{p,1}$  of size  $n_1 = |\mathcal{I}_{p,1}| \leq 4^p \cdot n$  is selected, where  $n = |V(G)|$ . There is a collection  $A_1 \subseteq \mathcal{I}_{p,1}$  of  $a_1 \leq p^2$  sets and a collection  $B_1 \subseteq \mathcal{I}_{p,1}$  of  $b_1 \leq p \cdot 4^p$  sets such that if every set in  $A_1$  is selected and no set in  $B_1$  is selected, then (E1–E3) hold. Instead of selecting a random subset, we try every function  $f$  in an  $(n_1, a_1 + b_1, (a_1 + b_1)^2)$ -splitter family and every subset  $F \subseteq [(a_1 + b_1)^2]$  of size  $a_1$  (there are  $\binom{(a_1 + b_1)^2}{a_1} = 2^{O(p^3)}$  such sets  $F$ ). For a particular choice of  $f$  and  $F$ , we select those sets  $X \in \mathcal{I}_{p,1}$  for which  $f(X) \in F$ . By the definition of the splitter, there will be a function  $f$  that is injective on  $A_1 \cup B_1$ , and there is a subset  $F$  such that  $f(X) \in F$  for every  $A_1$  and  $f(X) \notin F$  for every  $B_1$ . For such an  $f$  and  $F$ , the selection will ensure that (E1–E3) hold.

In the second phase, we select a random subset of universe  $\mathcal{I}_{p,2}$  of size  $n_2 \leq pn$ , and there is a collection  $A_2 \subseteq \mathcal{I}_{p,2}$  of size  $a_2 \leq 2^p$  and a collection  $B_2 \subseteq \mathcal{I}_{p,2}$  of size  $b_2 \leq p^2$  such that if every set in  $A_2$  is selected and no set in  $B_2$  is selected, then (E4) and (E5) hold. As in the first phase, we can replace this random choice by enumerating the functions of an  $(n_2, a_2 + b_2, (a_2 + b_2)^2)$ -splitter and every subset  $\bar{F} \subseteq [(a_2 + b_2)^2]$  of size  $b_2$  (there are  $\binom{(a_2 + b_2)^2}{b_2} = 2^{O(p^3)}$  such sets  $\bar{F}$ ). This time, we select a set  $X \in \mathcal{I}_{p,2}$  if  $f(X)$  is *not* in  $\bar{F}$  and it is clear that there is an  $f$  and  $\bar{F}$  for which (E4) and (E5) hold.

Let us bound the number of branches of the algorithm. In both phases, the size of the splitter family is  $2^{O(p)} \cdot \log n$  and there are  $2^{O(p^3)}$  possible  $F$ . (Note that the splitter family can be constructed in time polynomial in the size of the family.) Thus the algorithm produces  $2^{O(p^3)} \cdot \log^2 n$  sets.  $\square$

## 4 Reduction to the bipedal case

Let  $(G, \mathbf{T}, W, p)$  be an instance of the  $\text{MULTICUT COMPRESSION}^*$  problem. Let us call a component of  $G \setminus W$  having at least two legs a *non-trivial component* of  $G$  w.r.t.  $W$  (when the context is clear, we will just refer to a non-trivial component). As the solution of  $\text{MULTICUT COMPRESSION}^*$  has to be a set  $S$  that is disjoint from  $W$  and a multiway cut of  $W$ , the number of non-trivial components is a lower bound on the size of the solution.

We present an algorithm that either solves the given instance of the MULTICUT COMPRESSION\* problem or produces a set of instances of the BIPEDAL MULTICUT COMPRESSION\* problem whose number is bounded by a function of  $p$  and such that if the considered instance of the MULTICUT COMPRESSION\* problem has a shadowless solution then one of the output instances of the BIPEDAL MULTICUT COMPRESSION\* problem has a solution. In addition, any (not necessarily shadowless) solution of any of these output instances is a solution of the input instance of the MULTICUT COMPRESSION\* problem. The key ingredient of this algorithm is a procedure that, given an instance of the MULTICUT COMPRESSION\* problem where at least one component has more than 2 legs, reduces this instance to a set of instances whose number is bounded by a function of  $p$  and such that in each instance either the parameter is decreased or the number of non-trivial components is increased.

The main idea for the branching is the following. Let  $B$  be a set of vertices in  $G \setminus W$  and let  $S$  be a hypothetical shadowless solution for MULTICUT COMPRESSION\*. We try to guess what happens to each vertex of  $B$  in the solution  $S$ . It is possible that a vertex  $v \in B$  is in  $S$ ; in this case, we delete  $v$  from the instance and reduce the parameter. Otherwise, as the solution is shadowless,  $v$  has to be in the same component as precisely one  $w \in W$  (since  $S$  is a multiway cut of  $W$ ). In this case, identifying  $v$  and  $w$  does not change the solution.

The following lemma formalizes these observations. Given a set  $B$  of vertices in  $G \setminus W$  and a function  $f : B \rightarrow W$ , we denote by  $G_f$  the graph obtained by replacing each set  $\{w\} \cup f^{-1}(w)$  with a single vertex (with removal of loops and multiple occurrences of edges). To simplify the presentation, we will assume that this new vertex is also named  $w$ . We denote by  $\mathbf{T}_f$  the set of terminal pairs where each vertex  $v \in B$  is replaced by  $f(v)$ , and we denote by  $\mathbf{T} \setminus v$  the set where every pair involving the vertex  $v$  is removed.

**Lemma 4.1.** *Let  $K$  be a non-trivial component of  $G \setminus W$  with set of legs  $\widehat{W}$  and let  $B \subseteq K$ . If  $(G, \mathbf{T}, W, p)$  has a shadowless solution, then one of the following statements is true.*

- *There is a  $v \in B$  such that the instance  $(G \setminus v, \mathbf{T} \setminus v, W, p - 1)$  has a shadowless solution.*
- *There is a function  $f : B \rightarrow \widehat{W}$  such that instance  $(G_f, \mathbf{T}_f, W, p)$  has a shadowless solution.*

*Moreover, if any of the above instances has a solution, then  $(G, \mathbf{T}, W, p)$  has a solution as well.*

*Proof.* Assume that  $(G, \mathbf{T}, W, p)$  has a shadowless solution  $S$ . Then it either intersects or does not intersect with  $B$ . In the former case, we can specify a  $v \in S \cap B$  such that  $S \setminus \{v\}$  is a shadowless solution of  $(G \setminus v, \mathbf{T} \setminus v, W, p - 1)$ . In the latter case, we can assign each  $v \in B$  precisely one vertex  $f(v)$  of  $\widehat{W}$  such that vertex  $v$  belongs to the same component of  $G \setminus S$  as  $f(v)$ . It is not hard to see that  $S$  is a shadowless solution of  $(G_f, \mathbf{T}_f, W, p)$ .

For the second statement, we observe that the existence of a solution for any of the above instances implies the existence of a solution for  $(G, \mathbf{T}, W, p)$ . This is certainly true in the first case, where we delete a vertex and decrease the parameter by 1. In the second case, the statement follows from the fact that replacing  $G$  with  $G_f$  by identifying vertices cannot make the problem any easier.  $\square$

Lemma 4.1 determines a set of recursive calls to be applied in order to find a solution for the given instance  $(G, \mathbf{T}, W, p)$  of the MULTICUT COMPRESSION\* problem, if a shadowless solution is guaranteed to exist. It is clear that in each step, the number of directions we branch into is bounded by a function of  $p$ ,  $|B|$ , and  $|W|$  (observe that the number of functions  $f : B \rightarrow \widehat{W}$  can be bounded by  $|\widehat{W}|^{|B|} \leq |W|^{|B|}$ ). However, in order to ensure that the size of the search tree is bounded, we need to ensure that the *height* of the search tree is bounded as well. This is obvious for the first type of branches, as  $p$  decreases. The following property ensures that in every branch of the second type, either the number of nontrivial components increases or we get an instance that trivially has no solution.

**Definition 4.2.** Let  $K$  be a non-trivial component and let  $\widehat{W} \subseteq W$  be its set of legs. Let  $B$  be a subset of  $K$ . We say that  $B$  is a shattering set if for any function  $f : B \rightarrow \widehat{W}$  one of the following statements is true regarding the instance  $(G_f, \mathbf{T}_f, W, p)$  of the MULTICUT COMPRESSION\*.

- There is a  $w \in \widehat{W}$  such that there is no  $w - (\widehat{W} \setminus \{w\})$  separator of size at most  $p$  in  $G_f[K \cup \widehat{W}]$ .
- The number of non-trivial components of  $G_f \setminus W$  is greater than the number of non-trivial components of  $G \setminus W$ .

Note that the first possibility includes the case when  $G_f[\widehat{W}]$  is not an independent set (recall that an  $X - Y$  separator is disjoint from  $X \cup Y$  by definition). In Section 4.1, we present a polynomial-time algorithm for finding a shattering set.

**Lemma 4.3.** Given an instance  $(G, \mathbf{T}, W, p)$  of the MULTICUT COMPRESSION\* problem and a component  $K$  of  $G \setminus W$  with more than two legs, we can find a shattering set  $B \subseteq K$  of size at most  $3p$  in polynomial time.

With Lemma 4.3 in mind, we are ready to prove Lemma 2.6, the main statement of this section.

*Proof (of Lemma 2.6).* The desired algorithm looks as follows. If the given instance  $(G, \mathbf{T}, W, p)$  of MULTICUT COMPRESSION\* satisfies one of the following cases, then we can determine the answer without any further branching:

- All the terminal pairs of  $\mathbf{T}$  are separated: solve the MULTIWAY CUT problem  $(G, W, p)$ .
- The parameter is zero while there are unseparated terminals: this is a “NO” instance.
- There is a  $w \in W$  such that there is no  $w - (W \setminus \{w\})$  separator of size at most  $p$  in  $G$ : this is a “NO” instance. The situation where  $W$  is not an independent set is a special subcase of this case.
- The number of non-trivial components is greater than  $p$ : this is a “NO” instance since each non-trivial component contributes at least one vertex to any solution.
- Every component has at most two legs: this is an instance of BIPEDAL MULTICUT COMPRESSION\* problem and hence it is returned as the output.

Otherwise, we choose a component  $K$  of  $G \setminus W$  having more than two legs, and use Lemma 4.3 to compute a shattering subset  $B$  of  $K$  of size at most  $3p$ . We apply recursively the branches specified in the statement of Lemma 4.1. If the “YES” answer is obtained on at least one of these branches, then we return “YES”. If all the branches return “NO”, we return “NO”. According to Lemma 4.1, the resulting answer is correct. Furthermore, assume that no one of branches produces a “YES” or “NO” answer. Then, according to Lemma 4.1, if the parent instance has a shadowless solution, then the instance on one of the branches has a shadowless solution. It is also not hard to notice that any solution for a branch instance can be easily transformed into a solution of the parent instance. Applying this argument inductively, we conclude that the same relationship exists between the original instance  $(G, \mathbf{T}, W, p)$  and the BIPEDAL MULTICUT COMPRESSION\* problem instances at the leaves of the recursion tree.

To bound the number of leaves of the recursion tree, let us define  $\kappa$  to be the number of nontrivial components. Observe that removing a vertex of  $V(G) \setminus W$  from  $G$  can decrease the number of nontrivial components only by at most one. Thus inspection of Lemma 4.1 shows that the measure  $2p - \kappa$  strictly decreases in each branch. This means that the height of the search tree is at most  $2p$ . The number of branches in each step can be bounded by  $3p + |W|^{3p}$ . Thus the number of leaves of the recursion tree can be generously bounded by  $2^{O((p+\log |W|)^3)}$ . Taking into account that the runtime *per node* of the recursion tree is polynomial, it follows that the runtime of this algorithm is  $O^*(2^{O((p+\log |W|)^3)})$ .  $\square$

## 4.1 Finding a shattering set

We try to find a shattering set by selecting a set that separates one leg from all the other. If it is *not* a shattering set, then we can characterize quite well how it can look like, and where should we continue our search for a shattering set. Let us start with two simple lemmas.

**Lemma 4.4.** *Let  $K$  be a non-trivial component with a set  $\widehat{W}$  of at least 3 legs. If  $G[M_1]$  and  $G[M_2]$  are both connected for two disjoint sets  $M_1, M_2 \subseteq K$ , then at most one of  $M_1$  and  $M_2$  can be a multiway cut of  $(G[K \cup \widehat{W}], \widehat{W})$ .*

*Proof.* Assume the opposite. Since no two vertices of  $\widehat{W}$  belong to the same component of  $G[K \cup \widehat{W}] \setminus M_1$  and  $|\widehat{W}| \geq 3$ , we can specify two vertices  $w'$  and  $w''$  of  $\widehat{W}$  whose respective components  $C'$  and  $C''$  in  $G[K \cup \widehat{W}] \setminus M_1$  are disjoint from the connected set  $M_2$ . As  $G[K]$  is connected, there is a  $w' - w''$  path in  $G[K \cup \widehat{W}]$  that first uses vertices from  $C'$ , then vertices from (the connected set)  $M_1$ , then vertices from  $C''$ . This path is disjoint from  $M_2$ , contradicting the assumption that  $M_2$  is a multiway cut.  $\square$

**Lemma 4.5.** *Let  $K$  be a non-trivial component with a set  $\widehat{W}$  of at least 3 legs. Let  $B \subseteq K$  be a non-shattering set. Then there is exactly one connected component of  $G[K \setminus B]$  that is a multiway cut of  $(G[K \cup \widehat{W}], \widehat{W})$ .*

*Proof.* Let  $f : B \rightarrow \widehat{W}$  be the mapping witnessing that  $B$  is not a shattering set. Let  $K' \subseteq K \setminus B$  be the unique non-trivial component of  $G_f \setminus W$  that is a subset of  $K$  (witnessing  $B$  being a non-shattering set). As every neighbor of  $K'$  is in  $B \cup \widehat{W}$ , it is easy to see that  $K'$  is a component of  $G[K \setminus B]$  as well. Furthermore, we claim that  $K'$  is a multiway cut of  $(G[K \cup \widehat{W}], \widehat{W})$ . Otherwise, a path between vertices of  $\widehat{W}$  in  $G[K \cup \widehat{W}] \setminus K'$  would correspond to a walk of  $G_f$  between the same vertices which belong to a non-trivial component that is a subset of  $K$  but different from  $K'$ , in contradiction to the definition of  $f$ . Finally, Lemma 4.4 implies that  $K'$  is the unique connected component of  $G[K \setminus B]$  being a multiway cut of  $G[K \cup \widehat{W}]$ .  $\square$

Let  $K$  be a non-trivial component with a set of legs  $\widehat{W}$ . Let  $M \subseteq K$  be a multiway cut of  $(G[K \cup \widehat{W}], \widehat{W})$ . We call  $N(M)$  (i.e., the open neighborhood of  $M$ ) the *boundary* of  $M$  (which possibly includes vertices of  $\widehat{W}$ ). For each  $w \in \widehat{W}$ , the *image*  $I(w)$  of  $w$  is the set of vertices of  $N(M)$  reachable from  $w$  in  $G[K \cup \widehat{W}] \setminus M$  (the image may include vertex  $w$  itself, but it cannot include any other member of  $\widehat{W}$ ), see Figure 7. Note that  $I(w)$  is nonempty for any  $w \in \widehat{W}$ : consider the first vertex of  $N(M)$  on a path from  $w$  to some other leg in  $\widehat{W}$ . Furthermore, as  $M$  is a multiway cut, the sets  $I(w')$  and  $I(w'')$  are disjoint for  $w' \neq w''$ : otherwise, there would be a  $w' - w''$  path disjoint from  $M$ . For  $X \subseteq \widehat{W}$ , we let  $I(X) = \bigcup_{w \in X} I(w)$ . Let us select a distinguished leg  $w^* \in \widehat{W}$ . We say that  $M$  is *good* if all of the following conditions are true.

- $G[M]$  is connected,
- $N(M) = I(\widehat{W})$  or, in other words, each vertex of  $N(M)$  is reachable in  $G[K \cup \widehat{W}] \setminus M$  from some vertex of  $\widehat{W}$ , and
- $|I(w^*) \setminus \widehat{W}| \leq p$  and  $|I(\widehat{W} \setminus \{w^*\}) \setminus \widehat{W}| \leq p$  holds (and hence we have  $|N(M) \setminus \widehat{W}| \leq 2p$ ).

Our goal is to obtain a shattering set from the boundary of a good multiway cut. The following lemma gives a polynomial-time algorithm that either produces a shattering set, or finds a smaller good multiway cut. Interestingly, the algorithm does not check that the returned set  $B$  is a shattering using Definition 4.2 directly: this would require trying every function  $f : B \rightarrow \widehat{W}$ . Instead, the way the set  $B$  is produced guarantees that  $B$  is indeed a shattering set.

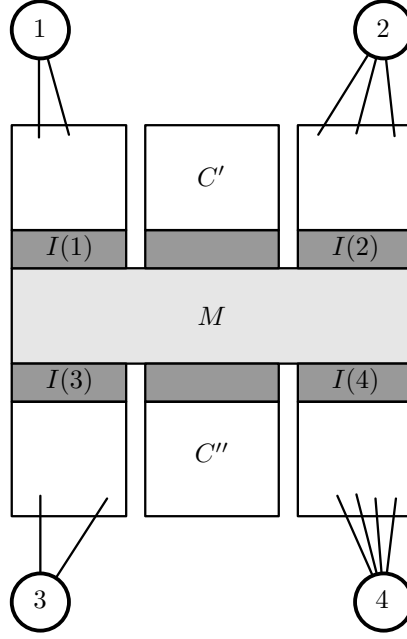

Figure 7:  $M$  is a multiway cut of the 4 legs  $\{1, 2, 3, 4\}$ . The dark region represents the boundary of  $M$ . Observe that  $I(\{1, 2, 3, 4\})$  is a proper subset of the boundary: vertices of the boundary that are adjacent only to  $C'$  and  $C''$  are not in  $I(w)$  for any  $w \in \{1, 2, 3, 4\}$ .

**Lemma 4.6.** *Let  $K$  be a non-trivial component with a set  $\widehat{W}$  of at least 3 legs and a distinguished leg  $w^*$ . Let  $M$  be a good multiway cut of  $(G[K \cup \widehat{W}], \widehat{W})$ . Then there is a polynomial-time algorithm that either returns a shattering set of size at most  $3p$  or a good multiway cut  $M' \subset M$ .*

*Proof.* The desired algorithm first computes a smallest  $I(w^*) - I(\widehat{W} \setminus \{w^*\})$  separator  $S$  of  $G[N(M) \cup M]$  (recall that the images are nonempty). Observe that  $S$  is an inclusionwise minimal  $w^* - \widehat{W} \setminus \{w^*\}$  separator in  $G[K \cup \widehat{W}]$  (and hence nonempty). We consider three cases:

1. If  $|S| > p$ , then the algorithm returns  $B := N(M) \setminus \widehat{W}$  reporting it as a shattering set.
2. If  $|S| \leq p$  and there is a unique connected component  $M'$  of  $G[K \setminus (N(M) \cup S)]$  that is a multiway cut of  $(G[K \cup \widehat{W}], \widehat{W})$ , then the algorithm returns  $M'$  reporting it as a good multiway cut.
3. If  $|S| \leq p$  and there is no such unique  $M'$ , then the algorithm returns  $B := (N(M) \cup S) \setminus \widehat{W}$  reporting it as a shattering set.

This algorithm clearly takes polynomial time. The remaining proof establishes correctness of the algorithm in each of these three cases.

**Case 1.** The definition of good multiway cut implies that that  $B := N(M) \setminus \widehat{W}$  has size at most  $2p$ . We prove that  $B$  is a shattering set. Otherwise, let  $f : B \rightarrow \widehat{W}$  be a function witnessing that  $B$  is not a shattering set. It is not hard to see that  $M$  is a connected component in  $G_f \setminus \widehat{W}$  whose set of legs is a subset of  $\widehat{W}$ . We consider three subcases and arrive to a contradiction in each of them (see Figure 8).

**Case 1a.**  $M$  is a trivial component of  $G_f \setminus \widehat{W}$ . Let  $w$  be the only leg of  $M$ . Let  $w_1$  and  $w_2$  be other two distinct legs of  $K$  in  $G$  that are different from  $w$ . It follows that  $f$  maps every vertex of  $I(w_1) \cup I(w_2)$  to  $w$  implying that there is a  $w - w_1$  and a  $w - w_2$  path in  $G_f$  whose internal vertices

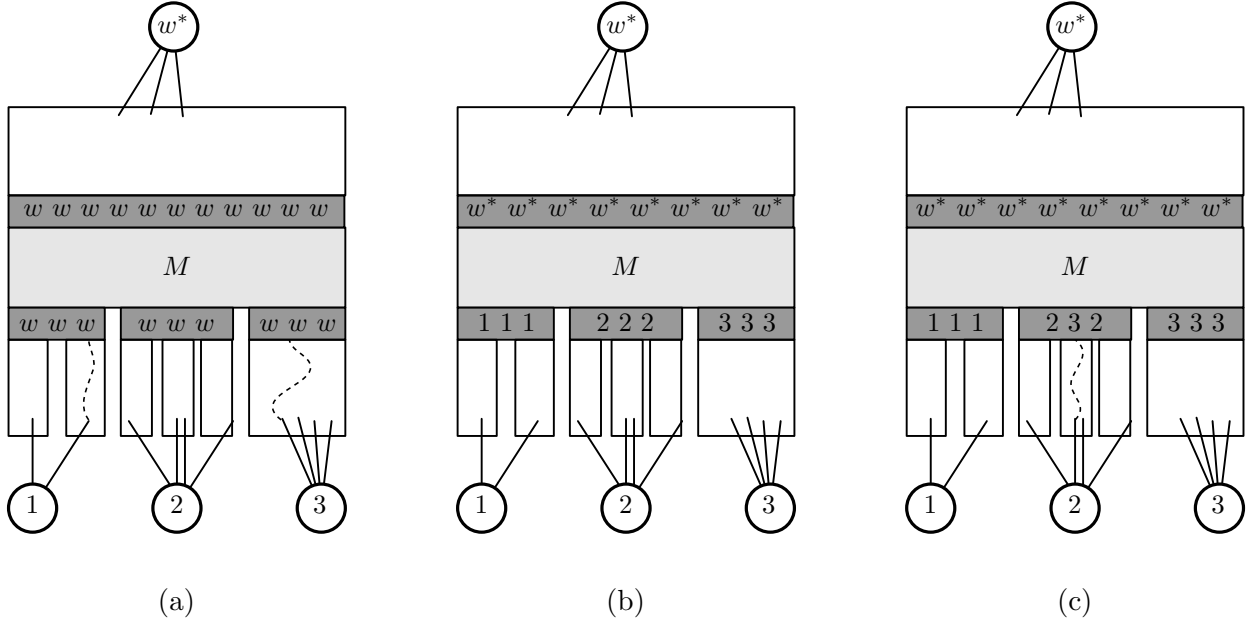

Figure 8: The 3 subcases of Case 1 in Lemma 4.6 for a component with legs  $\{w^*, 1, 2, 3\}$ . Case 1a:  $w$  is the only leg of  $M$  in  $G_f \setminus W$ . The figure shows two paths in two distinct components connecting  $w$  to another leg (assuming  $w \notin \{1, 3\}$ ). Case 1b:  $f(v) = w$  for every  $v \in I(w)$ . Case 1c:  $M$  is a nontrivial component in  $G_f \setminus W$  and  $f(v) = 3$  for some  $v \in I(2)$ ; the figure shows a 2 – 3 path.

belong to two different components adjacent to  $w_1$  and  $w_2$  in  $G[K \cup \widehat{W}] \setminus M$ . Thus  $G_f$  has at least two non-trivial components that are subsets of  $K$ , in contradiction to the choice of  $f$ .

**Case 1b.**  $M$  is a nontrivial component of  $G_f \setminus W$  and  $f(v) = w$  for every  $v \in I(w)$  and  $w \in \widehat{W}$  (i.e., each vertex on the boundary is mapped to its preimage). As the smallest  $I(w^*) - I(\widehat{W} \setminus \{w^*\})$  separator in  $G[N(M) \cup M]$  is larger than  $p$ ,  $G[M \cup \widehat{W}]$  does not have a  $w^* - \widehat{W} \setminus \{w^*\}$  separator of size at most  $p$ , in contradiction to  $f$  being a witnessing function.

**Case 1c.**  $M$  is a nontrivial component of  $G_f \setminus W$  and there are distinct  $w_1, w_2 \in \widehat{W}$  such that  $f(v) = w_2$  for some  $v \in I(w_1)$ . By definition of  $I(w_1)$ , there is a  $w_1 - v$  path in  $G$  whose internal vertices are fully contained in  $K \setminus M$ . Therefore, there is a  $w_1 - w_2$  path in  $G_f$  whose internal vertices are disjoint from  $M$ , implying that  $G_f$  has a nontrivial component that is a subset of  $K$ , but distinct from the nontrivial component  $M$ . Thus the number of nontrivial components increases, a contradiction.

**Case 2.** We show that  $M' \subset M$  and  $M'$  is a good multiway cut in this case. Let us show  $M' \subset M$  first. Clearly,  $M' \neq M$ , as  $M'$  is disjoint from the (nonempty) set  $S \subseteq M$ . Thus  $M' \not\subset M$  is only possible if  $M'$  is disjoint from  $M$ , but Lemma 4.4 implies that the two disjoint connected sets  $M$  and  $M'$  cannot be both multiway cuts.

For clarity, from now on we use  $I_M(w)$  and  $I_{M'}(w)$  for the image of  $w$  on the boundary of  $M$  and  $M'$ , respectively. Observe that  $I_M(w) \cap N(M') \subseteq I_{M'}(w)$  for every  $w \in \widehat{W}$ : for every  $v \in I_M(w) \cap N(M')$ , there is a  $w - v$  path disjoint from  $M$ , which is obviously disjoint from  $M' \subset M$  as well, and then  $v \in N(M')$  implies  $v \in I_{M'}(w)$ . We claim that either  $I_M(w^*)$  or  $I_M(\widehat{W} \setminus \{w^*\})$  is disjoint from  $N(M')$ . Suppose that there are two vertices  $v_1 \in I_M(w^*) \cap N(M')$  and  $v_2 \in I_M(\widehat{W} \setminus \{w^*\}) \cap N(M')$ . Vertices  $v_1$  and  $v_2$  can be connected by a path  $P$  whose internal vertices are in  $M'$  (hence disjoint from  $S$ ), contradicting the fact that  $S$  is an  $I_M(w^*) - I_M(\widehat{W} \setminus \{w^*\})$



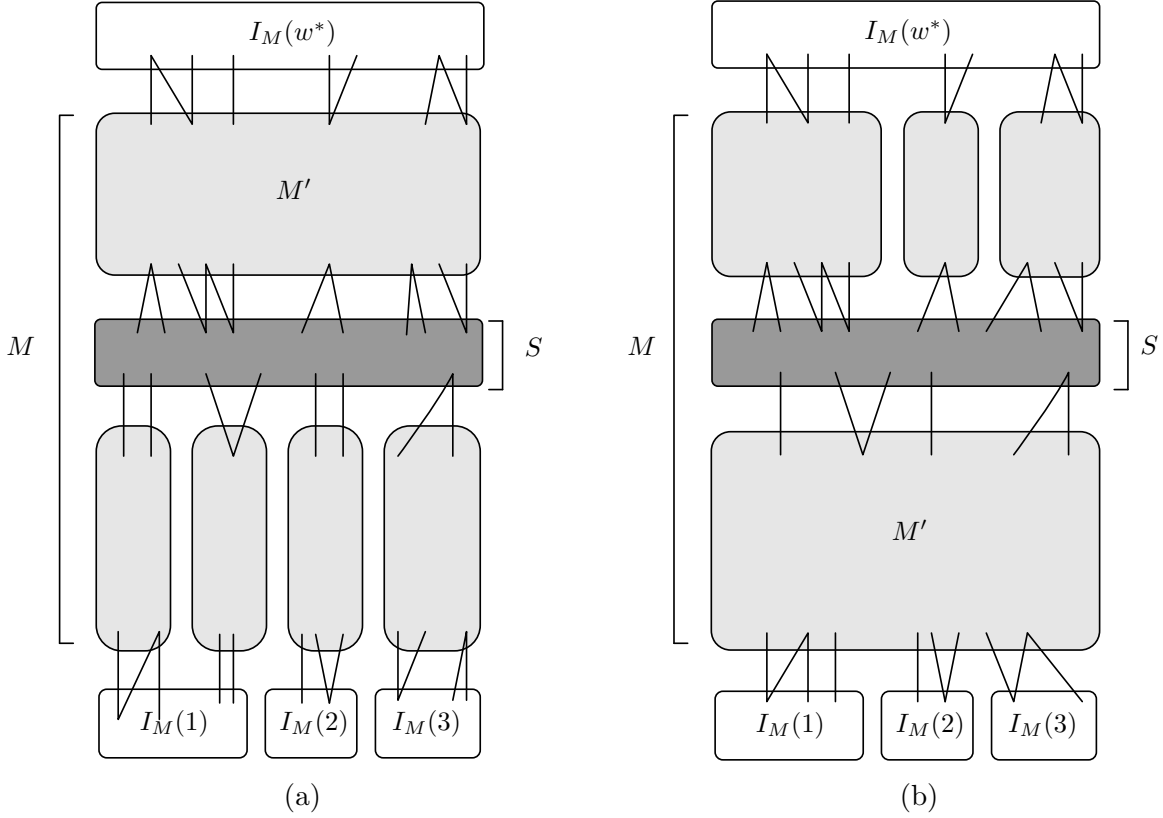

Figure 9: The two possibilities in Case 2 of Lemma 4.6 (the set of legs is  $\widehat{W} = \{w^*, 1, 2, 3\}$ ): either (a)  $N(M') \subseteq I_M(w^*) \cup S$  or (b)  $N(M') \subseteq I_M(\widehat{W} \setminus \{w^*\}) \cup S$  holds.

separator. Therefore, either  $N(M') \subseteq I_M(w^*) \cup S$  or  $N(M') \subseteq I_M(\widehat{W} \setminus \{w^*\}) \cup S$  holds. The two possibilities are demonstrated in Figure 9.

To show that  $|I_{M'}(w^*) \setminus \widehat{W}|$  and  $|I_{M'}(\widehat{W} \setminus \{w^*\}) \setminus \widehat{W}|$  are both at most  $p$ , we argue as follows. Suppose first that  $N(M') \subseteq I_M(w^*) \cup S$ . We show that  $I_{M'}(w^*) \subseteq I_M(w^*)$  and  $I_{M'}(\widehat{W} \setminus \{w^*\}) \subseteq S$  hold, proving the bounds  $|I_{M'}(w^*) \setminus \widehat{W}| \leq |I_M(w^*) \setminus \widehat{W}| \leq p$  and  $|I_{M'}(\widehat{W} \setminus \{w^*\}) \setminus \widehat{W}| \leq |S| \leq p$ . Let  $C_1$  (resp.,  $C_2$ ) be the union of all those components of  $G[\widehat{W} \cup (K \setminus M')]$  that contain a vertex of  $w^*$  (resp., a vertex of  $\widehat{W} \setminus \{w^*\}$ ). As  $M'$  is a multiway cut,  $C_1$  and  $C_2$  are disjoint. Now  $I_{M'}(w^*)$  and  $I_{M'}(\widehat{W} \setminus \{w^*\})$  are precisely the neighbors of  $M'$  in  $C_1$  and  $C_2$ , respectively. We observe that  $I_M(w^*) \subseteq C_1$ : if  $v \in I_M(w^*)$  is not in  $C_1$ , then every  $w^* - v$  path has to go through  $M' \subset M$ , contradicting the definition of  $I_M(w^*)$ . Thus  $N(M') \subseteq I_M(w^*) \cup S$  implies that every neighbor of  $M'$  in  $C_2$  is from  $S$  (as it cannot be from  $I_M(w^*) \subseteq C_1$ ), further implying  $I_{M'}(\widehat{W} \setminus \{w^*\}) \subseteq S$ . Next, we show that  $S \subseteq C_2$ . Suppose that there is a  $v \in S \setminus C_2$  and a  $w^* - \widehat{W} \setminus \{w^*\}$  path  $P$  intersecting  $S$  only in  $v$  (recall that  $S$  is a minimal  $w^* - \widehat{W} \setminus \{w^*\}$  separator). However, when the path  $P$  enters  $C_2$  from  $M'$ , then, as we have seen, it enters a vertex of  $S \cap C_2$  that is different from  $v$ , a contradiction. Thus  $N(M') \subseteq I_M(w^*) \cup S$  implies that every neighbor of  $M'$  in  $C_1$  is from  $I_M(w^*)$  (as it cannot be from  $S \subseteq C_2$ ), further implying  $I_{M'}(w^*) \subseteq I_M(w^*)$ . Finally, we can deduce that  $N(M') = I_{M'}(\widehat{W})$ , as required by the definition of good multiway cut: indeed, every vertex of  $N(M') \subseteq I_M(w^*) \cup S$  is

in  $C_1 \cup C_2$ , that is, either in  $I_{M'}(w^*)$  or in  $I_{M'}(\widehat{W} \setminus \{w^*\})$ . Therefore, we have shown that  $M' \subset M$  is a good multiway cut.

A symmetrical argument (exchanging the role of  $w^*$  and  $\widehat{W} \setminus \{w^*\}$ ) shows that if  $N(M') \subseteq I_M(\widehat{W} \setminus \{w^*\}) \cup S$ , then  $I_{M'}(w^*) \subseteq S$  and  $I_{M'}(\widehat{W} \setminus \{w^*\}) \subseteq I_M(\widehat{W} \setminus \{w^*\})$ , implying the bounds  $|I_{M'}(w^*) \setminus \widehat{W}| \leq p$  and  $|I_{M'}(\widehat{W} \setminus \{w^*\}) \setminus \widehat{W}| \leq p$ . Thus in both cases, we proved that  $M' \subset M$  is a good multiway cut.

**Case 3.** Assume now that the algorithm returns  $B := (S \cup N(M)) \setminus \widehat{W}$  as a shattering set. This happens because the number of components of  $G[K \setminus (N(M) \cup S)]$  which are multiway cuts of  $(G[K \cup \widehat{W}], \widehat{W})$  is not exactly one. According to Lemma 4.5,  $N(M) \cup S$  is indeed a shattering set in this case. Clearly, its size is at most  $3p$ .  $\square$

Lemma 4.3 follows by iterative application of Lemma 4.6.

*Proof (of Lemma 4.3).* It is not hard to see that  $K$  is a good multiway cut of  $(G[K \cup \widehat{W}], \widehat{W})$ ; in particular,  $I(w) = \{w\}$  for every  $w \in \widehat{W}$ , and hence  $I(w^*) \setminus \widehat{W} = I(\widehat{W} \setminus \{w^*\}) = \emptyset$ . Let  $M_0 = K$ . Apply the algorithm of Lemma 4.6 to  $M_0$ . The algorithm either returns a shattering set of size at most  $3p$  or a good multiway cut  $M_1 \subset M_0$ . In the former case, we return the shattering set, in the latter case, apply the algorithm of Lemma 4.6 to  $M_1$ . Continuing this way, we obtain a sequence  $M_0 \supset M_1 \supset \dots$  of good multiway cuts of decreasing size. It follows that after at most  $|V(G)|$  iterative applications of the algorithm of Lemma 4.6, a shattering set of size at most  $3p$  will be returned.  $\square$

## 5 Finding a shadowless solution by reduction to Almost 2SAT

The goal of this section is to show that we can solve BIPEDAL MULTICUT COMPRESSION\* if we know that there is at least one shadowless solution.

Let  $x_1, \dots, x_n$  be a set of variables; a literal is either a variable  $x_i$  or its negation  $\bar{x}_i$ . Recall that a 2CNF formula is a conjunction of clauses with at most two literals in each clause, e.g.,  $(\bar{x}_1 \vee x_2) \wedge (\bar{x}_3) \wedge (x_1 \vee \bar{x}_4)$ . The classical 2SAT problem asks if a given 2CNF formula has a satisfying assignment. It is well-known that a satisfying assignment for a 2CNF formula can be found in linear time (if exists). However, it is NP-hard to find an assignment that maximizes the number of satisfied clauses, or equivalently, to find a minimum set of clauses whose removal makes the formula satisfiable. Lokshtanov et al. [32] (improving earlier work [42, 14, 41]) gave an  $O^*(2.3146^k)$  time algorithm for the problem of deciding if a 2CNF formula can be made satisfiable by the deletion of at most  $k$  clauses; they call this problem ALMOST 2SAT. We need a variant of the result here, where instead of deleting at most  $k$  clauses, we are allowed to delete at most  $k$  variables. An easy reduction (see Appendix B) gives an algorithm for this variant. If  $\phi$  is a 2CNF formula and  $X$  is a set of variables, then we denote by  $\phi \setminus X$  the formula obtained by removing every clause containing a literal of a variable in  $X$ .

**Theorem 5.1.** *Given a 2CNF formula  $\phi$  and an integer  $k$ , in time  $O^*(2.3146^k)$  we can either find a set  $X$  of at most  $k$  variables such that  $\phi \setminus X$  is satisfiable, or correctly state that no such set  $X$  exists.*

It is not difficult to reduce finding a shadowless solution to the problem solved by Theorem 5.1. For each vertex  $v$  of  $G \setminus W$ , we introduce a variable whose value expresses which leg of the component containing  $v$  is reachable from  $v$ . This formulation cannot express that a vertex is separated from both legs. However, as we assume that there is a shadowless solution, we do not have to worry about such vertices.

*Proof (of Lemma 2.7).* We encode the BIPEDAL MULTICUT COMPRESSION\* instance  $I = (G, \mathbf{T}, W, p)$  as a 2CNF formula  $\phi$  the following way. For each component  $C$  of  $G \setminus W$  having two legs, let  $\ell_0(C)$  and  $\ell_1(C)$  be the two legs. If component  $C$  has only one leg, then let  $\ell_0(C)$  be this leg, and let  $\ell_1(C)$  be undefined. For every vertex  $v \in C$ , let  $\ell_0(v) = \ell_0(C)$  and  $\ell_1(v) = \ell_1(C)$ . We construct a formula  $\phi$  whose variables correspond to  $V(G) \setminus W$ . The intended meaning of the variables is that  $v$  has value  $b \in \{0, 1\}$  if  $v$  is in the same component as  $\ell_b(v)$  after removing the solution. To enforce this interpretation,  $\phi$  contains the following clauses:

- Group 1:  $(u \rightarrow v), (v \rightarrow u)$  for every adjacent  $u, v \in V(G) \setminus W$ .
- Group 2: If  $u$  is a neighbor of  $\ell_b(u)$  for some  $b \in \{0, 1\}$ , then there is a clause  $(u = b)$ .
- Group 3: If  $(u, v) \in \mathbf{T}$ ,  $u, v \notin W$ , and  $\ell_{b_u}(u) = \ell_{b_v}(v)$  for some  $b_u, b_v \in \{0, 1\}$ , then there is a clause  $(u \neq b_u \vee v \neq b_v)$  (e.g., if  $\ell_0(u) = \ell_1(v)$ , then the clause is  $(u \vee \bar{v})$ ).
- Group 4: If  $(u, v) \in \mathbf{T}$ ,  $u \in W$ ,  $v \notin W$ , and  $\ell_b(v) = u$  for some  $b \in \{0, 1\}$ , then there is a clause  $(v \neq b)$ .

This completes the description of  $\phi$ . Note that no clause is introduced for pairs  $(u, v) \in \mathbf{T}$  with  $u, v \in W$ , but these pairs are automatically separated by a solution that is a multiway cut of  $W$ . Furthermore, we can assume that  $W$  induces an independent set, otherwise there is no solution.

We show first that if  $I$  has a shadowless solution  $S$ , then removing the corresponding variables of  $\phi$  makes it satisfiable. As  $S$  is shadowless and it is a multiway cut of  $W$ , every vertex of  $G \setminus S$  is in the same component as exactly one of  $\ell_0(v)$  and  $\ell_1(v)$ ; let the value of variable  $v$  be  $b$  if vertex  $v$  is in the same component as  $\ell_b(v)$ . It is clear that this assignment satisfies the clauses in the first two groups. Consider a clause  $(u \neq b_u \vee v \neq b_v)$  from the third group. This means that  $(u, v) \in \mathbf{T}$  and  $\ell_{b_u}(u) = \ell_{b_v}(v) = w \in W$ . If this clause is not satisfied, then  $u = b_u$  and  $v = b_v$ . By the way the assignment was defined, this is only possible if  $u$  is in the same component of  $G \setminus S$  as  $\ell_{b_u}(u) = w$  and  $v$  is in the same component of  $G \setminus S$  as  $\ell_{b_v}(v) = w$ . Therefore,  $u$  and  $v$  are in the same component of  $G \setminus S$ , contradicting the assumption that  $S$  is a solution of  $I$ . Clauses in Group 4 can be checked similarly.

We have shown that  $\phi$  can be made satisfiable by the deletion of  $p$  variables. By Theorem 5.1, we can find such a set  $S'$  of variables in time  $O^*(4^p)$ . To complete the proof, we show that such a set  $S'$  corresponds to a (not necessarily shadowless) solution of  $I$ . Let us show first that  $S'$  is a multiway cut of  $W$ . Suppose that there is a path  $P$  connecting  $w_0, w_1 \in W$  in  $G \setminus S'$ . We can assume that the internal vertices of  $P$  are disjoint from  $W$ , i.e., they are in one component  $C$  of  $G \setminus W$  with two legs. Thus there is a path  $P'$  from a neighbor  $v_0$  of  $w_0$  to a neighbor  $v_1$  of  $w_1$  in  $C \setminus S'$ . Suppose without loss of generality that  $\ell_0(C) = w_0$  and  $\ell_1(C) = w_1$ . As the clauses in Group 1 are satisfied, every variable of  $P'$  has the same value. However, because of the clauses in Group 2, we have  $x_{v_0} = 0$  and  $x_{v_1} = 1$ , a contradiction. Therefore, we can assume that  $S'$  is a multiway cut of  $W$ .

Suppose now that there is some  $(u, v) \in \mathbf{T}$  such that  $u, v \notin W$  are in the same component of  $G \setminus S'$ ; let  $P$  be a  $u - v$  path in  $G \setminus S'$ . As  $W$  is a multicut of  $\mathbf{T}$ , it is clear that  $P$  goes through at least one vertex of  $W$ . We have seen that  $S'$  is a multiway cut of  $W$ , thus  $P$  goes through exactly one vertex of  $W$ . Let  $P = P_1 w P_2$  for some path  $P_1$  that is fully contained in the component of  $G \setminus W$  containing  $u$  and path  $P_2$  fully contained in the component containing  $v$ . Let  $b_u, b_v \in \{0, 1\}$  be such that  $\ell_{b_u}(u) = \ell_{b_v}(v) = w$ . Group 1 ensures that every variable of  $P_1$  has the same value and Group 2 ensures that the last variable of  $P_1$  has value  $b_u$ , thus  $u = b_u$ . A similar argument shows that  $v = b_v$ . However, this means that clause  $(u \neq b_u \vee v \neq b_v)$  of Group 3 is not satisfied, a contradiction. Finally, a similar argument shows that the clauses in Group 4 ensure that pairs  $(u, v) \in \mathbf{T}$  with  $u \in W$ ,  $v \notin W$  are separated.  $\square$

## 6 Hardness of DIRECTED MULTICUT

We prove that DIRECTED EDGE MULTICUT is  $W[1]$ -hard parameterized by the solution size, thus it is not fixed-parameter tractable (assuming the widely-held complexity hypothesis  $FPT \neq W[1]$ ). Recall that the edge and vertex versions are equivalent, thus the hardness result holds for both versions. The proof below proves the hardness result for the weighted version of the problem, where each edge has a positive integer weight, and the task is to find a multicut with total weight at most  $p$ . If the weights are polynomial in the size of the input (which is true in the proof), then the weighted version can be reduced to the unweighted version by introducing parallel edges. Thus the proof proves the hardness of the unweighted version as well. For notational convenience, we allow edges with weight  $\infty$ ; such edges can be easily replaced by edges with sufficiently large finite weight.

**Theorem 6.1.** *DIRECTED EDGE MULTICUT is  $W[1]$ -hard parameterized by the size  $p$  of the cutset.*

*Proof.* We prove hardness for the weighted version of the problem by parameterized reduction from CLIQUE. Let  $G$  be a graph with  $m$  edges and  $n$  vertices where a clique of size  $t$  has to be found. We construct an instance of DIRECTED EDGE MULTICUT containing  $t(t-1)$  gadgets: for each ordered pair  $(i, j)$  ( $1 \leq i, j \leq t$ ,  $i \neq j$ ), there is a gadget  $G_{i,j}$ . Intuitively, each gadget  $G_{i,j}$  has  $2m$  possible states and a state represents an ordered pair  $(v_i, v_j)$  of adjacent vertices. We would like to ensure that the gadgets describe a  $t$ -clique  $\{v_1, \dots, v_t\}$  in the sense that  $G_{i,j}$  represents the pair  $(v_i, v_j)$ . In order to enforce this interpretation, we need to connect the gadgets in a way that enforces two properties:

- (1) if  $G_{i,j}$  represents  $(v_i, v_j)$ , then  $G_{j,i}$  represents  $(v_j, v_i)$ , and
- (2) if  $G_{i,j}$  represents  $(v_i, v_j)$  and  $G_{i,j'}$  represents  $(u_i, u_j)$ , then  $v_i = u_i$ .

(Note that it follows from these two conditions that if  $G_{i,j}$  and  $G_{i',j}$  represent  $(v_i, v_j)$  and  $(u_i, u_j)$ , respectively, then  $v_j = u_j$ .)

Let us identify the vertices of  $G$  with the integers  $0, \dots, n-1$  and let us define  $\iota(x, y) = xn + y$ , which is a bijective mapping from  $\{0, \dots, n-1\} \times \{0, \dots, n-1\}$  to  $\{0, \dots, n^2-1\}$ . The gadget  $G_{i,j}$  has  $n^2 + 1$  vertices  $w_{i,j}^0, \dots, w_{i,j}^{n^2}$ . Let  $D := 2t^2$ . For every  $0 \leq s < n^2$ , there is an edge  $\overrightarrow{w_{i,j}^s w_{i,j}^{s+1}}$  whose weight is  $D$  if  $\iota^{-1}(s)$  is a pair  $(x, y)$  such that  $x$  and  $y$  are adjacent in  $G$ , and  $\infty$  otherwise. Furthermore, there is an additional edge  $\overrightarrow{w_{i,j}^{n^2} w_{i,j}^0}$  with weight  $\infty$ . The DIRECTED EDGE MULTICUT instance contains the terminal pair  $(w_{i,j}^0, w_{i,j}^{n^2})$ , which means that at least one of the edges  $\overrightarrow{w_{i,j}^s w_{i,j}^{s+1}}$  having finite weight has to be in the multicut. If the multicut contains exactly one such edge  $\overrightarrow{w_{i,j}^s w_{i,j}^{s+1}}$  in the gadget, then we say that the gadget *represents* the pair  $\iota^{-1}(s)$ . We set  $p := t(t-1)D + t + t(t-1)/2$  to be the maximum weight of the multicut. Since  $p < t(t-1)D + D$ , a multicut of weight at most  $p$  contains exactly one edge of weight  $D$  from each gadget, implying that each gadget represents some pair.

For every  $1 \leq i < j \leq t$ , we connect  $G_{i,j}$  and  $G_{j,i}$  in a way that ensures that if  $G_{i,j}$  represents the pair  $(x, y)$ , then  $G_{j,i}$  represents the pair  $(y, x)$  (see Fig. 10). More precisely, we show that if the multicut contains exactly one edge of the connection and  $G_{i,j}$  (resp.,  $G_{j,i}$ ) represents the pair  $(x, y)$  (resp.,  $(x', y')$ ), then  $x = y'$  and  $y = x'$ . For every ordered pair  $(x, y)$  of adjacent vertices of  $G$ , let us introduce two new vertices  $a_{i,j}^{(x,y)}, b_{i,j}^{(x,y)}$ , and the directed edge  $\overrightarrow{a_{i,j}^{(x,y)} b_{i,j}^{(x,y)}}$  having weight 1. Furthermore, let us add the edges  $\overrightarrow{w_{i,j}^{\iota(x,y)} a_{i,j}^{(x,y)}}$  and  $\overrightarrow{w_{j,i}^{\iota(y,x)} a_{i,j}^{(x,y)}}$  having weight  $\infty$ . Finally, let us add the terminal pairs  $(w_{i,j}^{\iota(x,y)+1}, b_{i,j}^{(x,y)})$  and  $(w_{j,i}^{\iota(y,x)+1}, b_{i,j}^{(x,y)})$ . Observe that if  $G_{i,j}$  represents  $(x, y)$ ,

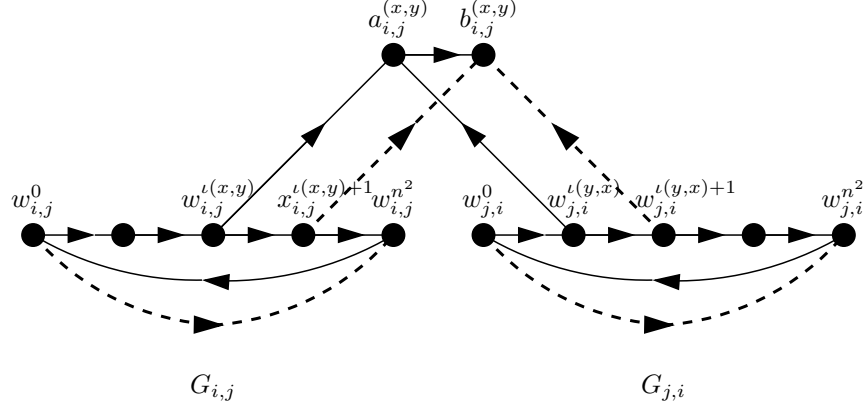

Figure 10: Part of a connection between gadgets  $G_{i,j}$  and  $G_{j,i}$  in the proof of Theorem 6.1. The dashed edges represent terminal pairs.

then  $w_{i,j}^{\iota(x,y)}$  (and hence  $a_{i,j}^{(x,y)}$ ) is reachable from  $w_{i,j}^{\iota(x,y)+1}$ , which means that the multicut has to contain the edge  $\overrightarrow{a_{i,j}^{(x,y)}, b_{i,j}^{(x,y)}}$ . Similarly, if  $G_{j,i}$  represents  $(x', y')$ , then  $w_{j,i}^{\iota(x',y')}$  (and hence  $a_{i,j}^{(y',x')}$ ) is reachable from  $w_{j,i}^{\iota(x',y')+1}$ , which means that the multicut has to contain the edge  $\overrightarrow{a_{i,j}^{(y',x')}, b_{i,j}^{(y',x')}}.$  If the multicut contains only one edge of the connection between  $G_{i,j}$  and  $G_{j,i}$ , the two edges must coincide, and we have  $x = y', y = x'$ .

For every  $1 \leq i \leq t$  and  $0 \leq x < n$ , we introduce two new vertices  $c_i^x$  and  $d_i^x$  and connect them with the edge  $\overrightarrow{c_i^x, d_i^x}$  having weight 1. For every  $1 \leq j \leq t, i \neq j, 0 \leq x < n$ , we add an edge  $\overrightarrow{w_{i,j}^{\iota(x,0)}, c_i^x}$  having weight  $\infty$  and a terminal pair  $(w_{i,j}^{\iota(x+1,0)}, d_i^x)$ . This completes the description of the reduction. Note that if  $G_{i,j}$  represents  $(x, y)$ , then  $\iota(x,0) \leq \iota(x, y) < \iota(x+1,0)$  implies that  $w_{i,j}^{\iota(x,0)}$  is reachable from  $w_{i,j}^{\iota(x+1,0)}$ , which means that the edge  $\overrightarrow{c_i^x, d_i^x}$  has to be in the cut to prevent  $d_i^x$  from being reachable from  $w_{i,j}^{\iota(x+1,0)}$ .

Suppose there is a multicut of weight at most  $p$ . This means that the multicut contains at most  $t(t-1)$  edges of weight  $D$ , thus each gadget  $G_{i,j}$  contains exactly one edge of weight  $D$ , i.e., each gadget represents some pair  $(x, y)$ . As discussed in the previous two paragraphs, if  $G_{i,j}$  represents  $(x, y)$ , then  $\overrightarrow{c_i^x, d_i^x}$  is in the multicut. Furthermore, depending on whether  $i < j$  or  $i > j$  holds, either  $\overrightarrow{a_{i,j}^{(x,y)}, b_{i,j}^{(x,y)}}$  or  $\overrightarrow{a_{j,i}^{(y,x)}, b_{j,i}^{(y,x)}}$ , respectively, is in the multicut as well. If the weight of the multicut is at most  $p$ , then the total weight of these edges is at most  $t + t(t-1)$ , which is only possible if these edge coincide in every possible way and it follows that properties (1) and (2) hold. Therefore, there are distinct vertices  $v_1, \dots, v_t$  such that gadget  $G_{i,j}$  represents  $(v_i, v_j)$ , which implies that  $v_1, \dots, v_t$  is a clique in  $G$ .

For the other direction, suppose that  $v_1, \dots, v_t$  is a clique in  $G$ . Let us consider the multicut that contains the following edges:

- $\overrightarrow{w_{i,j}^{\iota(v_i, v_j)}, w_{i,j}^{\iota(v_i, v_j)+1}}$  for every  $1 \leq i, j \leq t, i \neq j$ ,
- $\overrightarrow{a_{i,j}^{(v_i, v_j)}, b_{i,j}^{(v_i, v_j)}}$  for every  $1 \leq i < j \leq t$ , and
- $\overrightarrow{c_i^{v_i}, d_i^{v_i}}$  for every  $1 \leq i \leq t$ .

The total weight of these edges is exactly  $p$ . The edges in the first group ensure that  $w_{i,j}^{n^2}$  is not reachable from  $w_{i,j}^0$  for any  $i, j$ . For some  $i < j$  and adjacent vertices  $x$  and  $y$ , consider a terminal

pair  $(w_{i,j}^{\iota(x,y)+1}, b_{i,j}^{\iota(x,y)})$ . If  $(x, y) \neq (v_i, v_j)$ , then edge  $\overrightarrow{w_{i,j}^{\iota(v_i,v_j)} w_{i,j}^{\iota(v_i,v_j)+1}}$  of the multicut ensures that  $w_{i,j}^{\iota(x,y)}$  (and hence  $b_{i,j}^{\iota(x,y)}$ ) is not reachable from  $w_{i,j}^{\iota(x,y)+1}$ . If  $(x, y) = (v_i, v_j)$ , then edge  $\overrightarrow{a_{i,j}^{\iota(v_i,v_j)} b_{i,j}^{\iota(v_i,v_j)}}$  is in the multicut, again disconnecting this terminal pair. For  $i > j$ , an analogous argument shows that terminal pair  $(w_{i,j}^{\iota(x,y)+1}, b_{j,i}^{\iota(y,x)})$  for every  $x, y$  is disconnected. Consider now the terminal pair  $(w_{i,j}^{\iota(x+1,0)}, d_i^x)$  for some  $1 \leq i, j \leq t$ ,  $i \neq j$ ,  $0 \leq x < n$ . If  $x \neq v_i$ , then  $\iota(v_i, v_j)$  is either less than  $\iota(x, 0)$  or at least  $\iota(x + 1, 0)$ , thus the edge  $\overrightarrow{w_{i,j}^{\iota(v_i,v_j)} w_{i,j}^{\iota(v_i,v_j)+1}}$  of the multicut ensures that  $w_{i,j}^{\iota(x,0)}$  (and hence  $d_i^x$ ) is not reachable from  $w_{i,j}^{\iota(x+1,0)}$ . On the other hand, if  $x = v_i$ , then the edge  $\overrightarrow{c_i^{v_i} d_i^{v_i}}$  is in the third group of the multicut. Thus we have shown that if there is a clique of size  $t$  in  $G$ , then there is a multicut of size at most  $p$ . □

## Acknowledgement

We would like to thank the reviewers for the insightful comments that have helped us to fix a number of errors and improve readability.

## References

- [1] S. Arora, S. Rao, and U. Vazirani. Expander flows, geometric embeddings and graph partitioning. *J. ACM*, 56(2):1–37, 2009.
- [2] N. Bansal, A. Blum, and S. Chawla. Correlation clustering. *Machine Learning*, 56(1-3):89–113, 2004.
- [3] H. L. Bodlaender, M. R. Fellows, P. Heggernes, F. Mancini, C. Papadopoulos, and F. A. Rosamond. Clustering with partial information. *Theor. Comput. Sci.*, 411(7-9):1202–1211, 2010.
- [4] N. Bousquet, J. Daligault, and S. Thomassé. Multicut is FPT. In *Proceedings of the 43rd ACM Symposium on Theory of Computing*, pages 459–468, 2011.
- [5] N. Bousquet, J. Daligault, S. Thomasse, and A. Yeo. A polynomial kernel for multicut in trees. In *STACS*, pages 183–194, 2009.
- [6] G. Calinescu, C. G. Fernandes, and B. Reed. Multicuts in unweighted graphs and digraphs with bounded degree and bounded tree-width. *Journal of Algorithms*, 48(2):333 – 359, 2003.
- [7] S. Chawla, R. Krauthgamer, R. Kumar, Y. Rabani, and D. Sivakumar. On the hardness of approximating multicut and sparsest-cut. *Comput. Complexity*, 15(2):94–114, 2006.
- [8] J. Chen, Y. Liu, and S. Lu. An improved parameterized algorithm for the minimum node multiway cut problem. *Algorithmica*, 55(1):1–13, 2009.
- [9] J. Chen, Y. Liu, S. Lu, B. O’Sullivan, and I. Razgon. A fixed-parameter algorithm for the directed feedback vertex set problem. *J. ACM*, 55(5), 2008.
- [10] R. Chitnis, L. Egri, and D. Marx. List H-coloring a graph by removing few vertices. To appear in proceedings of ESA 2013.

- [11] R. Chitnis, M. Hajiaghayi, and D. Marx. Fixed-parameter tractability of Directed Multiway Cut parameterized by the size of the cutset. To appear in *SIAM Journal on Computing*.
- [12] R. H. Chitnis, M. Cygan, M. T. Hajiaghayi, and D. Marx. Directed Subset Feedback Vertex Set is fixed-parameter tractable. In *ICALP (1)*, pages 230–241, 2012.
- [13] J. Chuzhoy and S. Khanna. Polynomial flow-cut gaps and hardness of directed cut problems. *J. ACM*, 56(2):1–28, 2009.
- [14] M. Cygan, M. Pilipczuk, M. Pilipczuk, and J. O. Wojtaszczyk. On multiway cut parameterized above lower bounds. *TOCT*, 5(1):3, 2013.
- [15] E. Dahlhaus, D. S. Johnson, C. H. Papadimitriou, P. D. Seymour, and M. Yannakakis. The complexity of multiterminal cuts. *SIAM J. Comput.*, 23(4):864–894, 1994.
- [16] E. D. Demaine, D. Emanuel, A. Fiat, and N. Immerlica. Correlation clustering in general weighted graphs. *Theor. Comput. Sci.*, 361(2-3):172–187, 2006.
- [17] R. G. Downey and M. R. Fellows. *Parameterized Complexity*. Springer, New York, 1999.
- [18] U. Feige, M. Hajiaghayi, and J. R. Lee. Improved approximation algorithms for minimum weight vertex separators. *SIAM J. Comput.*, 38(2):629–657, 2008.
- [19] J. Flum and M. Grohe. *Parameterized Complexity Theory*. Springer, Berlin, 2006.
- [20] L. R. Ford, Jr. and D. R. Fulkerson. Maximal flow through a network. *Canad. J. Math.*, 8:399–404, 1956.
- [21] L. R. Ford, Jr. and D. R. Fulkerson. *Flows in networks*. Princeton University Press, Princeton, N.J., 1962.
- [22] N. Garg, V. V. Vazirani, and M. Yannakakis. Approximate max-flow min-(multi)cut theorems and their applications. *SIAM J. Comput.*, 25(2):235–251, 1996.
- [23] G. Gottlob and S. T. Lee. A logical approach to multicut problems. *Inf. Process. Lett.*, 103(4):136–141, 2007.
- [24] S. Guillemot. FPT algorithms for path-transversal and cycle-transversal problems. *Discrete Optimization*, 8(1):61 – 71, 2011.
- [25] J. Guo, F. Hüffner, E. Kenar, R. Niedermeier, and J. Uhlmann. Complexity and exact algorithms for vertex multicut in interval and bounded treewidth graphs. *European J. Oper. Res.*, 186(2):542–553, 2008.
- [26] J. Guo and R. Niedermeier. Fixed-parameter tractability and data reduction for multicut in trees. *Networks*, 46(3):124–135, 2005.
- [27] A. Gupta. Improved results for directed multicut. In *SODA*, pages 454–455, 2003.
- [28] F. Hüffner, R. Niedermeier, and S. Wernicke. Techniques for practical fixed-parameter algorithms. *The Computer Journal*, 51(1):7–25, 2008.
- [29] S. Khot. On the power of unique 2-prover 1-round games. In *STOC*, pages 767–775, 2002.

- [30] S. Kratsch, M. Pilipczuk, M. Pilipczuk, and M. Wahlström. Fixed-parameter tractability of multicut in directed acyclic graphs. In *ICALP (1)*, pages 581–593, 2012.
- [31] D. Lokshтанov and D. Marx. Clustering with local restrictions. *Inf. Comput.*, 222:278–292, 2013.
- [32] D. Lokshтанov, N. S. Narayanaswamy, V. Raman, M. S. Ramanujan, and S. Saurabh. Faster parameterized algorithms using linear programming. *CoRR*, abs/1203.0833, 2012.
- [33] D. Lokshтанov and M. S. Ramanujan. Parameterized tractability of multiway cut with parity constraints. In *ICALP (1)*, pages 750–761, 2012.
- [34] D. Marx. Parameterized graph separation problems. In *IWPEC*, pages 71–82, 2004.
- [35] D. Marx. Parameterized graph separation problems. *Theoretical Computer Science*, 351(3):394–406, 2006.
- [36] D. Marx and I. Razgon. Constant ratio fixed-parameter approximation of the edge multicut problem. *Inf. Process. Lett.*, 109(20):1161–1166, 2009.
- [37] D. Marx and I. Razgon. Fixed-parameter tractability of multicut parameterized by the size of the cutset. In *Proceedings of the 43rd ACM Symposium on Theory of Computing*, pages 469–478, 2011.
- [38] M. Naor, L. J. Schulman, and A. Srinivasan. Splitters and near-optimal derandomization. In *FOCS*, pages 182–191, 1995.
- [39] R. Niedermeier. *Invitation to Fixed-Parameter Algorithms*. Oxford University Press, 2006.
- [40] R. Pichler, S. Rümmele, and S. Woltran. Multicut algorithms via tree decompositions. In *CIAC*, pages 167–179, 2010.
- [41] V. Raman, M. S. Ramanujan, and S. Saurabh. Paths, flowers and vertex cover. In *ESA*, pages 382–393, 2011.
- [42] I. Razgon and B. O’Sullivan. Almost 2-SAT is fixed-parameter tractable. *J. Comput. Syst. Sci.*, 75(8):435–450, 2009.
- [43] B. Reed, K. Smith, and A. Vetta. Finding odd cycle transversals. *Operations Research Letters*, 32(4):299–301, 2004.
- [44] J. Sherman. Breaking the multicommodity flow barrier for  $O(\sqrt{\log n})$ -approximations to sparsest cut. In *FOCS*, pages 363–372, 2009.
- [45] M. Xiao. Algorithms for multiterminal cuts. In *CSR*, pages 314–325, 2008.
- [46] M. Yannakakis, P. C. Kanellakis, S. S. Cosmadakis, and C. H. Papadimitriou. Cutting and partitioning a graph after a fixed pattern. In *ICALP*, pages 712–722, 1983.



## A Important separators

First we state without proof some properties of Definition 3.8 that are easy to see:

**Proposition A.1.** *Let  $G$  be a graph,  $X, Y \subseteq V(G)$  be two disjoint sets of vertices, and  $S$  be an important  $X - Y$  separator.*

1. *For every  $v \in S$ , the set  $S \setminus \{v\}$  is an important  $X - Y$  separator in  $G \setminus v$ .*
2. *If  $S$  is an  $X' - Y$  separator for some  $X' \supset X$ , then  $S$  is an important  $X' - Y$  separator.*

*Proof (of Lemma 3.9).* We prove by induction on  $2p - \lambda$  that there are at most  $2^{2p-\lambda}$  important  $X - Y$  separators of size at most  $p$ , where  $\lambda$  is the size of the smallest  $X - Y$  separator. If  $\lambda > p$ , then there is no  $X - Y$  separator of size  $p$ , and therefore the statement holds if  $2p - \lambda < 0$ . Also, if  $\lambda = 0$  and  $p \geq 0$ , then there is a unique important  $X - Y$  separator of size at most  $p$ : the empty set.

If  $S$  is an  $X - Y$  separator, then we denote by  $K_S$  the union of every component of  $G \setminus S$  intersecting  $X$ . First we show the well-known fact that there is a unique  $X - Y$  separator  $S^*$  of size  $\lambda$  such that  $K_{S^*}$  is inclusionwise maximal, i.e., we have  $K_S \subseteq K_{S^*}$  for every other  $X - Y$  separator  $S$  of size  $\lambda$ . Suppose that there are two separators  $S'$  and  $S''$  such that  $K_{S'}$  and  $K_{S''}$  are incomparable and inclusionwise maximal. Let us define the function  $\gamma(Z) = |N(Z)|$ . It is well-known that  $\gamma$  is submodular, that is,

$$\gamma(A) + \gamma(B) \geq \gamma(A \cup B) + \gamma(A \cap B)$$

for every  $A, B \subseteq V(G)$ . In particular, the submodularity of gamma implies that

$$\underbrace{\gamma(K_{S'})}_{=\lambda} + \underbrace{\gamma(K_{S''})}_{=\lambda} \geq \gamma(K_{S'} \cup K_{S''}) + \underbrace{\gamma(K_{S'} \cap K_{S''})}_{\geq \lambda}.$$

The left hand side is exactly  $2\lambda$ , while the second term of the right hand side is at least  $\lambda$  (as  $N(K_{S'} \cap K_{S''})$  is an  $X - Y$  separator). Therefore,  $\gamma(K_{S'} \cup K_{S''}) \leq \lambda$ . This means that  $N(K_{S'} \cup K_{S''})$  is also a minimum  $X - Y$  separator, contradicting the maximality of  $S'$  and  $S''$ .

Next we show that for every important  $X - Y$  separator  $S$ , we have  $K_{S^*} \subseteq K_S$ . Suppose this is not true for some  $S$ . We use submodularity again:

$$\underbrace{\gamma(K_{S^*})}_{=\lambda} + \gamma(K_S) \geq \gamma(K_{S^*} \cup K_S) + \underbrace{\gamma(K_{S^*} \cap K_S)}_{\geq \lambda}.$$

By definition,  $\gamma(K_{S^*}) = \lambda$ , and  $N(K_{S^*} \cap K_S)$  is an  $X - Y$  separator, hence  $\gamma(K_{S^*} \cap K_S) \geq \lambda$ . This means that  $\gamma(K_{S^*} \cup K_S) \leq \gamma(K_S)$ . However this contradicts the assumption that  $S$  is an important  $X - Y$  separator:  $N(K_{S^*} \cup K_S)$  is an  $X - Y$  separator not larger than  $S$ , but  $K_{S^*} \cup K_S$  is a proper superset of  $K_S$  (as  $K_{S^*}$  is not a subset of  $K_S$  by assumption).

We have shown that for every important separator  $S$ , the set  $K_S$  contains  $K_{S^*}$ . Let  $v \in S^*$  be an arbitrary vertex of  $S^*$  (note that  $\lambda > 0$ , hence  $S^*$  is not empty). An important  $X - Y$  separator  $S$  of size at most  $p$  either contains  $v$  or not. If  $S$  contains  $v$ , then  $S \setminus \{v\}$  is an important  $X - Y$  separator in  $G \setminus v$  of size at most  $p' := p - 1$  (Prop. A.1(1)). As  $v \notin X, Y$ , the size  $\lambda'$  of the minimum  $X - Y$  separator in  $G \setminus v$  is at least  $\lambda - 1$ . Therefore,  $2p' - \lambda' < 2p - \lambda$  and the induction hypothesis implies that there are at most  $2^{2p'-\lambda'} \leq 2^{2p-\lambda-1}$  important  $X - Y$  separators of size  $p'$  in  $G \setminus \{v\}$ , and hence at most that many important  $X - Y$  separators of size  $p$  in  $G$  that contain  $v$ .

Let us count now the important  $X - Y$  separators not containing  $v$ . Note that by the minimality of  $S^*$ , vertex  $v$  of  $S^*$  has a neighbor in  $K_{S^*}$ . We have seen that  $K_{S^*} \subseteq K_S$  for every such  $X - Y$  separator  $S$ . As  $v \notin S$  and  $v$  has a neighbor in  $K_S$ , even  $K_{S^*} \cup \{v\} \subseteq K_S$  is true. Let  $X' = K_{S^*} \cup \{v\}$ ; it follows that  $S$  is a  $X' - Y$  separator and in fact an important  $X' - Y$  separator by Prop. A.1(2).

There is no  $X' - Y$  separator  $S$  of size  $\lambda$ : such a set  $S$  would be an  $X - Y$  separator of size  $\lambda$  as well, with  $K_{S^*} \cup \{v\} \subseteq K_S$ , contradicting the maximality of  $S^*$ . Thus the minimum size  $\lambda'$  of an  $X' - Y$  separator is greater than  $\lambda$ . It follows by the induction assumption that the number of important  $X' - Y$  separators of size at most  $p$  is at most  $2^{2p-\lambda'} \leq 2^{2p-\lambda-1}$ , which is a bound on the number of important  $X - Y$  separators of size  $p$  in  $G$  that does not contain  $v$ .

Adding the bounds in the two cases, we get the required bound  $2^{2p-\lambda}$ . An algorithm for enumerating all the at most  $4^p$  important separators follows from the above proof. First, we can find a maximum  $X - Y$  flow in time  $O(p(|V(G)| + |E(G)|))$  using at most  $p$  rounds of the Ford-Fulkerson algorithm. It is well-known that the separator  $S^*$  in the proof can be deduced from the maximum flow in linear time by finding those vertices from which  $Y$  cannot be reached in the residual graph [21]. Pick any arbitrary vertex  $v \in S^*$ . Then we branch on whether vertex  $v \in S^*$  is in the important separator or not, and recursively find all possible important separators for both cases. Note that this algorithm enumerates a superset of all important separators: by our analysis above, every important separator is found, but there is no guarantee that all the constructed separators are important. Therefore, the algorithm has to be followed by a filtering phase where we check for each returned separator whether it is important. Observe that  $S$  is an important  $X - Y$  separator if and only if  $S$  is the unique minimum  $K_S - Y$  separator, where  $K_S$  is the set of vertices reachable from  $X$  in  $G \setminus S$ . As the size of  $S$  is at most  $p$ , this can be checked in time  $O(p(|V(G)| + |E(G)|))$  by finding a maximum flow and constructing the residual graph. The search tree has at most  $4^p$  leaves and the work to be done in each node is  $O(p(|V(G)| + |E(G)|))$ . Therefore, the total running time of the branching algorithms is  $O(4^p \cdot p(|V(G)| + |E(G)|))$  and returns at most  $4^p$  separators. This is followed by the filtering phase, which takes time  $O(4^p \cdot p(|V(G)| + |E(G)|))$ .  $\square$

## B Deleting variables in Almost 2SAT

*Proof (of Theorem 5.1).* Let  $x_1, \dots, x_n$  be the variables of  $\phi$ . We create a new 2CNF formula  $\phi'$  on  $2n$  variables  $x_i^b$  ( $1 \leq i \leq n, b \in \{0, 1\}$ ). The intended meaning of  $x_i^b$  is that its value is 1 if and only if the value of  $x_i$  in  $\phi$  is  $b$ . For every  $1 \leq i \leq n$ , let us introduce a clause  $(\bar{x}_i^0 \vee \bar{x}_i^1)$  in formula  $\phi'$ . For every clause of  $\phi$ , there is a corresponding clause of  $\phi'$  where literal  $x_i$  is replaced by literal  $x_i^1$  and literal  $\bar{x}_i$  is replaced by  $x_i^0$  (e.g.,  $(x_i \vee \bar{x}_j)$  is replaced by  $(x_i^1 \vee x_j^0)$ ).

We claim that there is a set  $X$  of variables in  $\phi$  such that  $\phi \setminus X$  is satisfiable if and only if there is a set  $X'$  ( $|X| = |X'|$ ) of clauses in  $\phi'$  such that  $\phi' \setminus X'$  is satisfiable. As the existence of such a  $X'$  can be tested by the algorithm of [42] in time  $O^*(4^k)$ , the theorem follows from this claim.

Suppose first that there is such a set  $X$  of variables in  $\phi$ ; let  $f$  be a satisfying assignment of  $\phi \setminus X$ . Let  $X'$  contain the clauses  $(\bar{x}_i^0 \vee \bar{x}_i^1)$  for every  $x_i \in X$ . Let us define  $f'(x_i^0) = f'(x_i^1) = 1$  if  $x_i \in X$ , and for every  $x_i \notin X$ , let  $f'(x_i^b) = 1$  if and only if  $f(x_i) = b$ . It is straightforward to verify that  $f'$  satisfies  $\phi' \setminus X'$ .

For the other direction, let us suppose that  $X'$  is a set of clauses such that  $\phi' \setminus X'$  is satisfiable and let  $f'$  be a satisfying assignment of  $\phi' \setminus X'$ . The important observation is that we can assume that  $X'$  contains only clauses of the form  $(\bar{x}_i^0 \vee \bar{x}_i^1)$ . To see this, observe that variables  $x_i^b$  appear negatively only in the clauses of this form. Thus if  $X'$  contains a clause  $C$  that where  $x_i^b$  appears positively, then we can replace  $C$  in  $X'$  by  $(\bar{x}_i^0 \vee \bar{x}_i^1)$  and set  $f(x_i^0) = f(x_i^1) = 1$ . Let  $X$  contain a variable  $x_i$  if  $(\bar{x}_i^0 \vee \bar{x}_i^1)$  is in  $X'$ . It is easy to verify that defining  $f(x_i) = f(x_i^1)$  gives a satisfying assignment of  $\phi \setminus X$ .  $\square$